

exclusivo



Low thermal inertia



Low water consumption



Versatility



Easy to stock and install



16 bar
Working pressure



3 international patents



Mod. 700 - 800

CE¹⁴



STANDARD SUPPLY: Available from 3 to 10 sections for centre distance 800 – from 3 to 12 sections for centre distance 700 - from 3 to 14 sections for centre distance 350-500-600.

COLOUR: Ral 9010 White

Model	Heat output				
	ΔT 30	ΔT 40	ΔT 50	ΔT 60	ΔT 70
	W/sect.	W/sect.	W/sect.	W/sect.	W/sect.
B4 350/100	47,3	68,6	91,5	115,8	141,3
B3 500/100	59,6	86,4	115,2	145,8	177,8
B3 600/100	68,5	99,7	133,4	169,2	206,8
B3 700/100	77,1	112,0	149,5	189,4	231,3
B3 800/100	85,2	124,0	166,0	210,7	257,7

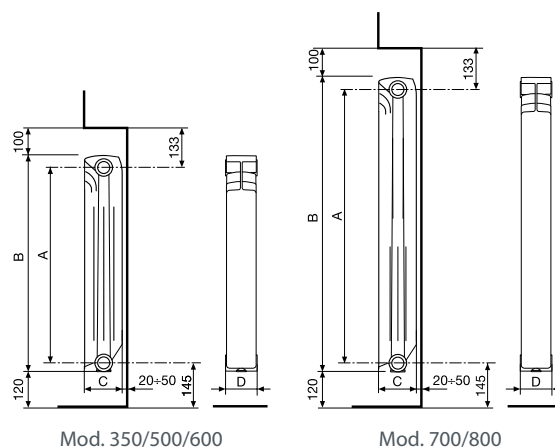

Model	Code	Depth	Height	Centre distance	Length	Connection diameters	Water capacity	Exponent	Coefficient
		(C) mm	(B) mm	(A) mm	(D) mm	inches	litres/sect.	n	Km
B4 350/100	V680014	97	407	350	80	G1	0,21	1,2910	0,5865
B3 500/100	V666034	97	557	500	80	G1	0,25	1,2896	0,7422
B3 600/100	V666044	97	657	600	80	G1	0,28	1,3046	0,8101
B3 700/100	V666054	97	757	700	80	G1	0,39	1,2970	0,9358
B3 800/100	V666064	97	857	800	80	G1	0,43	1,3070	0,9992

Maximum working pressure: 1600 kPa (16 bar)

Characteristic equation of the model $\Phi = Km \Delta T^n$.

The thermal efficiency values shown comply with the European Standard EN 442-1:2014 and are certified by the MRT Lab of the Milan Polytechnic, notified body N°1695.

Article	Code	Description
	A 80 550103	Mounting kit for radiators each containing: 2 zinc-plated. paint-coated reducers 1/2"G. Rh; 2 zinc-plated. paint-coated reducers 1/2"G. Lh; 4 retaining gaskets 1 manual air-purging valve 1/2"G with gasket; 1 (1/2"G) plug with gasket
	A 81 550104	Mounting kit for radiators each containing: 2 zinc-plated. paint-coated reducers 1/2"G. Rh; 2 zinc-plated. paint-coated reducers 1/2"G. Lh; 4 retaining gaskets; 1 manual air-purging valve 1/2"G with gasket; 1 (1/2"G) plug with gasket; 3 brackets to be screwed on to the wall
	A 2/1 510011	1"G joining nipple
	A 10/1 530105	Nipple gasket (asbestos-free)
	A 11/1 530108	Gasket for plugs (asbestos-free)
	A 20 550037	Installation kit with two adjustable, coated brackets

