



ITACA CH KR MODULES

EN





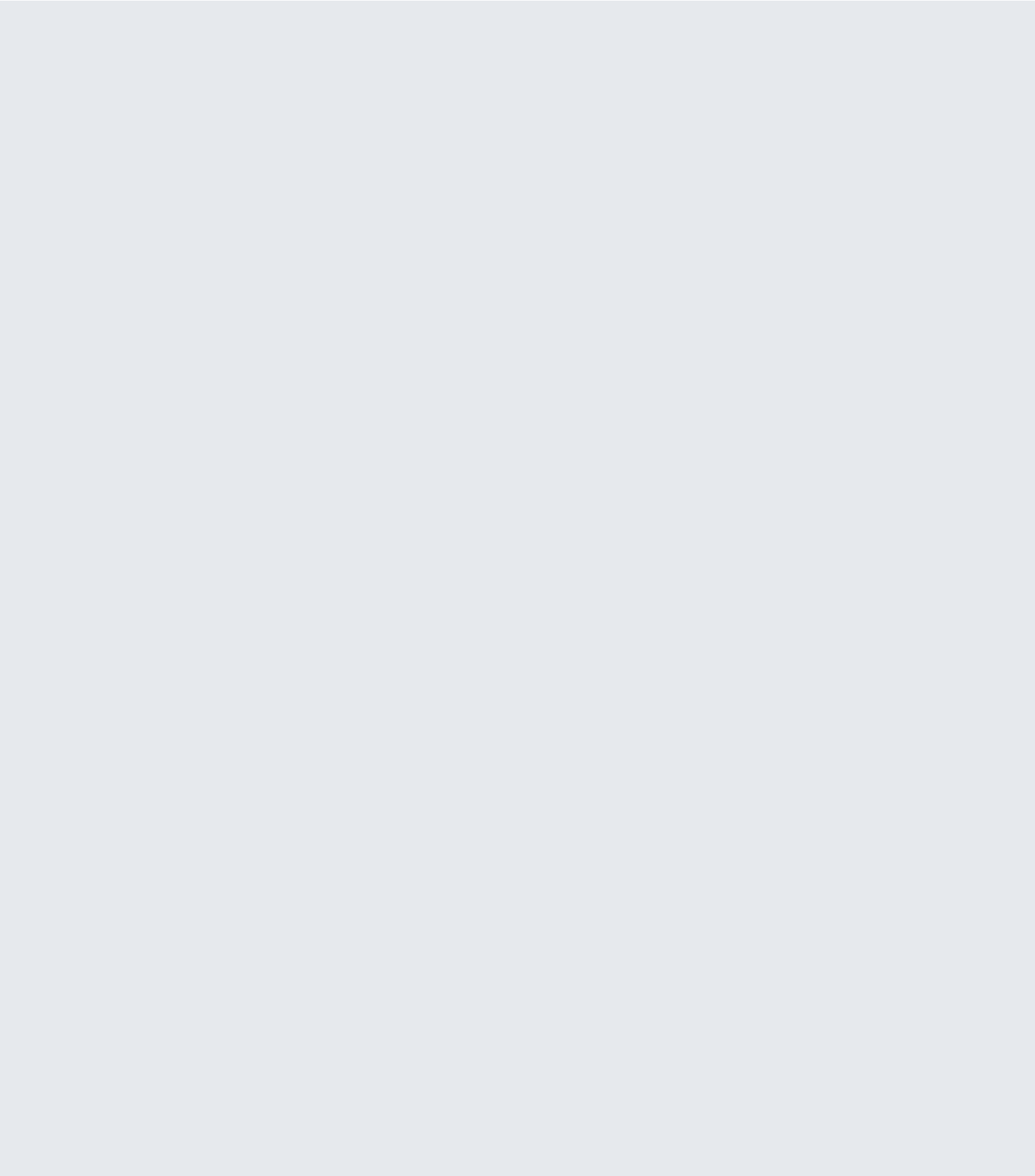



ITACA CH KR MODULES

ITACA CH KR - MODULE FOR INDOOR INSTALLATION

Product description and configurations	page 4
Configurations with direct collectors	page 15
Configurations with hydraulic separator	page 18
Configurations with plate exchanger	page 21

ITACA CH KR - BACK TO BACK MODULE FOR INDOOR INSTALLATION

Product description and configurations	page 24
Configurations with direct collectors	page 32
Configurations with hydraulic separator	page 33
Configurations with plate exchanger	page 34

ITACA CH KR - CABINET MODULE FOR OUTDOOR INSTALLATION

Product description and configurations	page 36
Configurations with direct collectors	page 47
Configurations with hydraulic separator	page 50
Configurations with plate exchanger	page 53

CASCADE MODULAR GENERATOR TECHNICAL DATA

PAGE 56

ACCESSORIES

PAGE 73

CODES

PAGE 77



ITACA CH KR MODULE FOR INDOOR INSTALLATION

MODULAR CONDENSING HEAT GENERATOR FOR COMMERCIAL HEATING



- ▶ **Multilingual user's interface**
- ▶ **High-efficiency stainless steel heat exchanger**
- ▶ **CH water flow rate double electronic control**
- ▶ **High modulation ratios: for single module up to 1:10; for modular generator up to 1:70**
- ▶ **Integrated cascade management system**
- ▶ **Possibility to connect up to 6 boilers in a cascade-type connection**
- ▶ **Integrated flue gas check valve**
- ▶ **Class 6 of NO_x emissions**

The declared efficiency class is not requested for output models above 70 kW.

Available in the following models:

from **45** to **900**



WARNING

The modular heat generators on supporting frame described in this section of the catalogue must be exclusively installed indoors. The outdoor installation is not included

-) Indoor installations on supporting structure
-) Under-boiler hydraulic unit to be installed with water (insulated) and gas collectors, high-efficiency circulation pump, water and gas connecting ramps
-) Two-way shut-off taps on flow and return
-) Alarm output or LPG valve control, input for external probe, ambient thermostat, hot water storage tank probe, connection for solar pump, plant pump
-) 0-10 V control on temperature or power
-) Cascade management with Master Slave system from boiler control panel
-) Supplied with flue gas duct
-) Total premix, steel, cylindrical burner that can run on several gases
-) Modulating gas valve with constant air/gas ratio
-) Variable speed combustion fan
-) Electrical protection class IPX4D
-) Electronic ignition and ionisation flame detection device
-) Temperature probes checking also the flow rate
-) Flow rate electronic control with flowmeter
-) Available in the following versions: with direct collectors; with hydraulic separator; with plate exchanger

MODULAR GENERATOR FOR INDOOR INSTALLATION ON FRAME

Each thermal module of the modular generator consists of the combination of the units described in the tables below. With the exception of the Itaca CH KR heat generators, all the described units must be assembled on site.

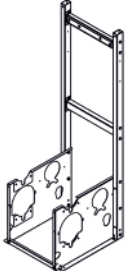
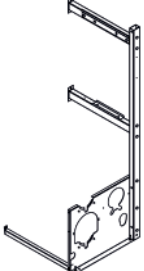
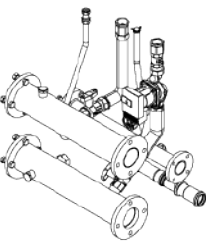
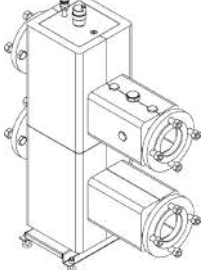
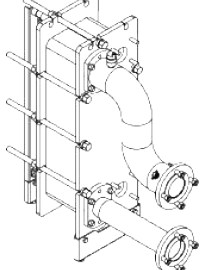
Item	Description
	<p>Heat generator Itaca CH KR in 45 – 60 – 85 – 120 – 150 kW outputs</p>
	<p>Head supporting frame It can be used as a self-supporting frame, to be used for a generator consisting of a single module or as a 'starting' frame for the series of generators.</p>
	<p>"Expansion" supporting frame To be used to add a maximum of 5 modules in series to the head supporting frame, for a maximum total number of 6 modules.</p>
	<p>Under-boiler hydraulic unit consisting of: <ul style="list-style-type: none"> - Flanged DN 80 PN 6 insulated flow - return collectors - DN 50 PN 6 flanged gas duct - Non-return valve - High efficiency circulation pump - Gas connecting pipes - Gas Tap - Hydraulic connecting pipes - Two-way taps for return and flow collector - Discharge pipes </p>
	<p>Hydraulic separator unit valid for all outputs up to 900 kW Insulated, with bleed valve, cascade probe holder, cascade probe, hydraulic gaskets, M16 screws and nuts for flange connection.</p>
	<p>Plate exchanger unit with collectors Available in 10 models to be matched to the offered modular generator output levels, it also features: <ul style="list-style-type: none"> - Connecting collectors between primary circuit and plates - Cascade probe holder - Cascade probe - Gaskets, screws and nuts for flange connection </p>



The modular generator is offered in the following configurations

Configuration with modular generator	
Direct collectors	Modular generator connected to the primary circuit without separating device in the hydraulic circuit (*)
With hydraulic separator	Modular generator with connection to the primary circuit, provided with hydraulic separator for the separation of the primary and secondary circuit
With plate exchanger	Modular generator with connection to the primary circuit, provided with plate exchanger for the separation of the primary and secondary circuit

(*) It is mandatory to combine a hydraulic separator or a plate exchanger to separate the primary circuit (cascade side) from the secondary circuit (plant side)

The modular generator is supplied with the following combinations of heating modules:

Model	Modules	Model	Modules
	Nr (nr x [model])		Nr (nr x [model])
45	1 (1 x 45)	450	3 (3 x 150)
60	1 (1 x 60)	480	4 (4 x 120)
85	1 (1 x 85)	510	4 (3 x 120 + 1 x 150)
90 (**)	2 (2 x 45)	540	4 (2 x 120 + 2 x 150)
105 (**)	2 (1 x 60 + 1 x 45)	570	4 (1 x 120 + 3 x 150)
120	1 (1 x 120)	600	4 (4 x 150)
150	1 (1 x 150)	630	5 (4 x 120 + 1 x 150)
170	2 (2 x 85)	660	5 (3 x 120 + 2 x 150)
205	2 (1 x 85 + 1 x 120)	690	5 (2 x 120 + 3 x 150)
240	2 (2 x 120)	720	5 (1 x 120 + 4 x 150)
270	2 (1 x 120 + 1 x 150)	750	5 (5 x 150)
300	2 (2 x 150)	780	6 (4 x 120 + 2 x 150)
325	3 (1 x 85 + 2 x 120)	810	6 (3x120 + 3 x 150)
360	3 (3 x 120)	870	6 (1 x 120 + 5 x 150)
390	3 (2 x 120 + 1 x 150)	900	6 (6 x 150)
420	3 (1 x 120 + 2 x 150)		

(**) Versions of modular generators offered to create a low power heating system, spread on 2 heat generators instead of 1

PRODUCT CONFIGURATION
BASIC COMBINATION WITH DIRECT COLLECTORS

Models	45	60	90 (**)	105 (**)
Itaca CH KR 45 heat generator	1	-	2	1
Itaca CH KR 60 heat generator	-	1	-	1
Support / start frame	1	1	1	1
Expansion frame	-	-	1	1
Under-module complete hydraulic unit	1	1	2	2
Insulated flow - return collectors	●	●	●	●
Gas duct	●	●	●	●
Water and gas connecting pipes	●	●	●	●
Flow - return 2-way tap, gas	●	●	●	●
Gas tap	●	●	●	●
Non-return valve	●	●	●	●
High-efficiency - head pump	PWM - 7.5 m	PWM - 8 m	PWM - 7.5 m	PWM - 8 m
Closing flange unit for water and gas collectors	1	1	1	1
Flue gas duct D 160	1	1	2	2
D 100 extension for boiler - collector flue gas drain connection	-	-	2	1
D 80 - 100 adapter for flue gas duct	1	1	2	2
D 80 air suction opening	1	1	2	2
D 160 cap for flue gas duct with condensate drain hole	1	1	1	1
Cascade collector probe	1	1	1	1
Heat transfer paste kit for cascade probe and safety devices on collector	1	1	1	1

(**) Versions of modular generators offered to create a low power heating system, spread on 2 heat generators instead of 1
Reference to images from page 15 on page17

**COMBINATION WITH HYDRAULIC SEPARATOR
CONSISTING OF THE BASIC COMBINATION WITH DIRECT COLLECTORS WITH THE ADDITION OF THE FOLLOWING COMPONENTS**

Models	45	60	90 (**)	105 (**)
Hydraulic separator, with insulation and support with adjustable feet	●	●	●	●
Kit of gaskets + screws and nuts for flange connection	●	●	●	●
Cascade probe holder	●	●	●	●
Automatic bleed on separator	●	●	●	●

(**) Versions of modular generators offered to create a low power heating system, spread on 2 heat generators instead of 1
Reference to images from page 18 on page20

**COMBINATION WITH PLATE EXCHANGER
CONSISTING OF THE BASIC COMBINATION WITH DIRECT COLLECTORS WITH THE ADDITION OF THE FOLLOWING COMPONENTS**

Models	45	60	90 (**)	105 (**)
AISI 304 stainless steel plate exchanger - sized according to power level	●	●	●	●
Insulated plate (*) cascade - primary circuit collectors connection kit	●	●	●	●
Kit of exchanger support brackets with adjustable feet	●	●	●	●
Automatic bleed for collector	●	●	●	●
Cascade probe holder	●	●	●	●
Kit of gaskets + screws and nuts for flange connection	●	●	●	●
Insulated system - plate secondary circuit collectors connection kit	●	●	●	●

(*) The collector unit for the connection of the secondary circuit of the plate exchanger according to the right or left position is available as an optional kit
(**) Versions of modular generators offered to create a low power heating system, spread on 2 heat generators instead of 1
Reference to images from page 21 on page23

BASIC COMBINATION WITH DIRECT COLLECTORS

Models	85	120	170
Itaca CH KR 85 heat generator	1	-	2
Itaca CH KR 120 heat generator	-	1	-
Support / start frame	1	1	1
Expansion frame	-	-	1
Under-module complete hydraulic unit	1	1	2
Insulated flow - return collectors	●	●	●
Gas duct	●	●	●
Water and gas connecting pipes	●	●	●
Flow - return 2-way tap, gas	●	●	●
Gas tap	●	●	●
Non-return valve	●	●	●
High-efficiency - head pump	PWM - 11 m	Self-adj., 12 m	PWM - 11 m
Closing flange unit for water and gas collectors	1	1	1
Flue gas duct D 160	1	1	2
D 100 extension for boiler - collector flue gas drain connection	1	1	2
D 80 - 100 adapter for flue gas duct	1	-	2
D 80 air suction opening	1	-	2
D 160 cap for flue gas duct with condensate drain hole	1	1	1
D 100 suction opening	-	1	-
Cascade collector probe	1	1	1
Heat transfer paste kit for cascade probe and safety devices on collector	1	1	1

Reference to images from page 15 on page17

COMBINATION WITH HYDRAULIC SEPARATOR CONSISTING OF THE BASIC COMBINATION WITH DIRECT COLLECTORS WITH THE ADDITION OF THE FOLLOWING COMPONENTS

Models	85	120	170
Hydraulic separator, with insulation and support with adjustable feet	●	●	●
Kit of gaskets + screws and nuts for flange connection	●	●	●
Cascade probe holder	●	●	●
Automatic bleed on separator	●	●	●

Reference to images from page 18 on page20

COMBINATION WITH PLATE EXCHANGER CONSISTING OF THE BASIC COMBINATION WITH DIRECT COLLECTORS WITH THE ADDITION OF THE FOLLOWING COMPONENTS

Models	85	120	170
AISI 304 stainless steel plate exchanger - sized according to power level	●	●	●
Insulated plate (*) cascade - primary circuit collectors connection kit	●	●	●
Kit of exchanger support brackets with adjustable feet	●	●	●
Automatic bleed for collector	●	●	●
Cascade probe holder	●	●	●
Kit of gaskets + screws and nuts for flange connection	●	●	●
Insulated system - plate secondary circuit collectors connection kit	●	●	●

(*) The collector unit for the connection of the secondary circuit of the plate exchanger according to the right or left position is available as an optional kit
Reference to images from page 21 on page23

BASIC COMBINATION WITH DIRECT COLLECTORS

Models	205	240	325
Itaca CH KR 85 heat generator	1	-	1
Itaca CH KR 120 heat generator	1	2	2
Support / start frame	1	1	1
Expansion frame	1	1	2
Under-module complete hydraulic unit	2	2	3
Insulated flow - return collectors	●	●	●
Gas duct	●	●	●
Water and gas connecting pipes	●	●	●
Flow - return 2-way tap, gas	●	●	●
Gas tap	●	●	●
Non-return valve	●	●	●
High-efficiency - head pump	PWM - 11 m Self-adj., 12 m (*)	Self-adj., 12 m	PWM - 11 m Self-adj., 12 m (*)
Closing flange unit for water and gas collectors	1	1	1
Flue gas duct D 160	2	2	-
D 100 extension for boiler - collector flue gas drain connection	2	2	2
D 80 - 100 adapter for flue gas duct	1	-	1
D 80 air suction opening	1	-	1
D 160 cap for flue gas duct with condensate drain hole	1	1	-
Flue gas duct D 200	-	-	3
Connection extension D 200	-	-	2
D 200 cap for flue gas duct with condensate drain hole	-	-	1
D 100 suction opening	1	2	2
Cascade collector probe	1	1	1
Heat transfer paste kit for cascade probe and safety devices on collector	1	1	1

(*) The PWM 11 m pump is matched with the hydraulic unit with 85 kW heat generator
Reference to images from page 15 on page17

COMBINATION WITH HYDRAULIC SEPARATOR CONSISTING OF THE BASIC COMBINATION WITH DIRECT COLLECTORS WITH THE ADDITION OF THE FOLLOWING COMPONENTS

Models	205	240	325
Hydraulic separator, with insulation and support with adjustable feet	●	●	●
Kit of gaskets + screws and nuts for flange connection	●	●	●
Cascade probe holder	●	●	●
Automatic bleed on separator	●	●	●

Reference to images from page 18 on page20

COMBINATION WITH PLATE EXCHANGER CONSISTING OF THE BASIC COMBINATION WITH DIRECT COLLECTORS WITH THE ADDITION OF THE FOLLOWING COMPONENTS

Models	205	240	325
AISI 304 stainless steel plate exchanger - sized according to power level	●	●	●
Insulated plate (*) cascade - primary circuit collectors connection kit	●	●	●
Kit of exchanger support brackets with adjustable feet	●	●	●
Automatic bleed for collector	●	●	●
Cascade probe holder	●	●	●
Kit of gaskets + screws and nuts for flange connection	●	●	●
Insulated system - plate secondary circuit collectors connection kit	●	●	●

(*) The collector unit for the connection of the secondary circuit of the plate exchanger according to the right or left position is available as an optional kit
Reference to images from page 21 on page23

BASIC COMBINATION WITH DIRECT COLLECTORS				
Models	150	270	300	360
Itaca CH KR 120 heat generator	-	1	-	3
Itaca CH KR 150 heat generator	1	1	2	-
Support / start frame	1	1	1	1
Expansion frame	-	1	1	2
Under-module complete hydraulic unit	1	2	2	3
Insulated flow - return collectors	●	●	●	●
Gas duct	●	●	●	●
Water and gas connecting pipes	●	●	●	●
Flow - return 2-way tap, gas	●	●	●	●
Gas tap	●	●	●	●
Non-return valve	●	●	●	●
High-efficiency - head pump	Self-adj., 12 m	Self-adj., 12 m	Self-adj., 12 m	Self-adj., 12 m
Closing flange unit for water and gas collectors	1	1	1	1
Flue gas duct D 160	1	2	2	-
D 100 extension for boiler - collector flue gas drain connection	1	2	2	3
D 160 cap for flue gas duct with condensate drain hole	1	1	1	-
Flue gas duct D 200	-	-	-	3
Connection extension D 200	-	-	-	2
D 200 cap for flue gas duct with condensate drain hole	-	-	-	1
D 100 suction opening	1	2	2	3
Cascade collector probe	1	1	1	1
Heat transfer paste kit for cascade probe and safety devices on collector	1	1	1	1

Reference to images from page 15 on page17

COMBINATION WITH HYDRAULIC SEPARATOR CONSISTING OF THE BASIC COMBINATION WITH DIRECT COLLECTORS WITH THE ADDITION OF THE FOLLOWING COMPONENTS				
Models	150	270	300	360
Hydraulic separator, with insulation and support with adjustable feet	●	●	●	●
Kit of gaskets + screws and nuts for flange connection	●	●	●	●
Cascade probe holder	●	●	●	●
Automatic bleed on separator	●	●	●	●

Reference to images from page 18 on page20

COMBINATION WITH PLATE EXCHANGER CONSISTING OF THE BASIC COMBINATION WITH DIRECT COLLECTORS WITH THE ADDITION OF THE FOLLOWING COMPONENTS				
Models	150	270	300	360
AISI 304 stainless steel plate exchanger - sized according to power level	●	●	●	●
Insulated plate (*) cascade - primary circuit collectors connection kit	●	●	●	●
Kit of exchanger support brackets with adjustable feet	●	●	●	●
Automatic bleed for collector	●	●	●	●
Cascade probe holder	●	●	●	●
Kit of gaskets + screws and nuts for flange connection	●	●	●	●
Insulated system - plate secondary circuit collectors connection kit	●	●	●	●

(*) The collector unit for the connection of the secondary circuit of the plate exchanger according to the right or left position is available as an optional kit
Reference to images from page 21 on page23

BASIC COMBINATION WITH DIRECT COLLECTORS

Models	390	420	450	480
Itaca CH KR 120 heat generator	2	1	-	4
Itaca CH KR 150 heat generator	1	2	3	-
Support / start frame	1	1	1	1
Expansion frame	2	2	2	3
Under-module complete hydraulic unit	3	3	3	4
Insulated flow - return collectors	●	●	●	●
Gas duct	●	●	●	●
Water and gas connecting pipes	●	●	●	●
Flow - return 2-way tap, gas	●	●	●	●
Gas tap	●	●	●	●
Non-return valve	●	●	●	●
High-efficiency - head pump	Self-adj., 12 m	Self-adj., 12 m	Self-adj., 12 m	Self-adj., 12 m
Closing flange unit for water and gas collectors	1	1	1	1
D 100 extension for boiler - collector flue gas drain connection	3	3	3	4
Flue gas duct D 200	3	3	3	4
Connection extension D 200	2	2	2	3
D 200 cap for flue gas duct with condensate drain hole	1	1	1	1
D 100 suction opening	3	3	3	4
Cascade collector probe	1	1	1	1
Heat transfer paste kit for cascade probe and safety devices on collector	1	1	1	1

Reference to images from page 15 on page17

COMBINATION WITH HYDRAULIC SEPARATOR CONSISTING OF THE BASIC COMBINATION WITH DIRECT COLLECTORS WITH THE ADDITION OF THE FOLLOWING COMPONENTS

Models	390	420	450	480
Hydraulic separator, with insulation and support with adjustable feet	●	●	●	●
Kit of gaskets + screws and nuts for flange connection	●	●	●	●
Cascade probe holder	●	●	●	●
Automatic bleed on separator	●	●	●	●

Reference to images from page 18 on page20

COMBINATION WITH PLATE EXCHANGER CONSISTING OF THE BASIC COMBINATION WITH DIRECT COLLECTORS WITH THE ADDITION OF THE FOLLOWING COMPONENTS

Models	390	420	450	480
AISI 304 stainless steel plate exchanger - sized according to power level	●	●	●	●
Insulated plate (*) cascade - primary circuit collectors connection kit	●	●	●	●
Kit of exchanger support brackets with adjustable feet	●	●	●	●
Automatic bleed for collector	●	●	●	●
Cascade probe holder	●	●	●	●
Kit of gaskets + screws and nuts for flange connection	●	●	●	●
Insulated system - plate secondary circuit collectors connection kit	●	●	●	●

(*) The collector unit for the connection of the secondary circuit of the plate exchanger according to the right or left position is available as an optional kit
Reference to images from page 21 on page23

BASIC COMBINATION WITH DIRECT COLLECTORS

Models	510	540	570	600
Itaca CH KR 120 heat generator	3	2	1	-
Itaca CH KR 150 heat generator	1	2	3	4
Support / start frame	1	1	1	1
Expansion frame	3	3	3	3
Under-module complete hydraulic unit	4	4	4	4
Insulated flow - return collectors	●	●	●	●
Gas duct	●	●	●	●
Water and gas connecting pipes	●	●	●	●
Flow - return 2-way tap, gas	●	●	●	●
Gas tap	●	●	●	●
Non-return valve	●	●	●	●
High-efficiency - head pump	Self-adj., 12 m	Self-adj., 12 m	Self-adj., 12 m	Self-adj., 12 m
Closing flange unit for water and gas collectors	1	1	1	1
D 100 extension for boiler - collector flue gas drain connection	4	4	4	4
Flue gas duct D 200	4	4	4	4
Connection extension D 200	3	3	3	3
D 200 cap for flue gas duct with condensate drain hole	1	1	1	1
D 100 suction opening	4	4	4	4
Cascade collector probe	1	1	1	1
Heat transfer paste kit for cascade probe and safety devices on collector	1	1	1	1

Reference to images from page 15 on page17

COMBINATION WITH HYDRAULIC SEPARATOR CONSISTING OF THE BASIC COMBINATION WITH DIRECT COLLECTORS WITH THE ADDITION OF THE FOLLOWING COMPONENTS

Models	510	540	570	600
Hydraulic separator, with insulation and support with adjustable feet	●	●	●	●
Kit of gaskets + screws and nuts for flange connection	●	●	●	●
Cascade probe holder	●	●	●	●
Automatic bleed on separator	●	●	●	●

Reference to images from page 18 on page20

COMBINATION WITH PLATE EXCHANGER CONSISTING OF THE BASIC COMBINATION WITH DIRECT COLLECTORS WITH THE ADDITION OF THE FOLLOWING COMPONENTS

Models	510	540	570	600
AISI 304 stainless steel plate exchanger - sized according to power level	●	●	●	●
Insulated plate (*) cascade - primary circuit collectors connection kit	●	●	●	●
Kit of exchanger support brackets with adjustable feet	●	●	●	●
Automatic bleed for collector	●	●	●	●
Cascade probe holder	●	●	●	●
Kit of gaskets + screws and nuts for flange connection	●	●	●	●
Insulated system - plate secondary circuit collectors connection kit	●	●	●	●

(*) The collector unit for the connection of the secondary circuit of the plate exchanger according to the right or left position is available as an optional kit
Reference to images from page 21 on page23

BASIC COMBINATION WITH DIRECT COLLECTORS

Models	630	660	690	720
Itaca CH KR 120 heat generator	4	3	2	1
Itaca CH KR 150 heat generator	1	2	3	4
Support / start frame	1	1	1	1
Expansion frame	4	4	4	4
Under-module complete hydraulic unit	5	5	5	5
Insulated flow - return collectors	●	●	●	●
Gas duct	●	●	●	●
Water and gas connecting pipes	●	●	●	●
Flow - return 2-way tap, gas	●	●	●	●
Gas tap	●	●	●	●
Non-return valve	●	●	●	●
High-efficiency - head pump	Self-adj., 12 m	Self-adj., 12 m	Self-adj., 12 m	Self-adj., 12 m
Closing flange unit for water and gas collectors	1	1	1	1
D 100 extension for boiler - collector flue gas drain connection	5	5	5	5
D 100 suction opening	5	5	5	5
Flue gas duct D 250	5	5	5	5
Connection extension D 250	4	4	4	4
D 250 cap for flue gas duct with condensate drain hole	1	1	1	1
Cascade collector probe	1	1	1	1
Heat transfer paste kit for cascade probe and safety devices on collector	1	1	1	1

Reference to images from page 15 on page17

COMBINATION WITH HYDRAULIC SEPARATOR CONSISTING OF THE BASIC COMBINATION WITH DIRECT COLLECTORS WITH THE ADDITION OF THE FOLLOWING COMPONENTS

Models	630	660	690	720
Hydraulic separator, with insulation and support with adjustable feet	●	●	●	●
Kit of gaskets + screws and nuts for flange connection	●	●	●	●
Cascade probe holder	●	●	●	●
Automatic bleed on separator	●	●	●	●

Reference to images from page 18 on page20

COMBINATION WITH PLATE EXCHANGER CONSISTING OF THE BASIC COMBINATION WITH DIRECT COLLECTORS WITH THE ADDITION OF THE FOLLOWING COMPONENTS

Models	630	660	690	720
AISI 304 stainless steel plate exchanger - sized according to power level	●	●	●	●
Insulated plate (*) cascade - primary circuit collectors connection kit	●	●	●	●
Kit of exchanger support brackets with adjustable feet	●	●	●	●
Automatic bleed for collector	●	●	●	●
Cascade probe holder	●	●	●	●
Kit of gaskets + screws and nuts for flange connection	●	●	●	●
Insulated system - plate secondary circuit collectors connection kit	●	●	●	●

(*) The collector unit for the connection of the secondary circuit of the plate exchanger according to the right or left position is available as an optional kit
Reference to images from page 21 on page23

BASIC COMBINATION WITH DIRECT COLLECTORS

Models	750	780	810	870	900
Itaca CH KR 120 heat generator	-	4	3	1	-
Itaca CH KR 150 heat generator	5	2	3	5	6
Support / start frame	1	1	1	1	1
Expansion frame	4	5	5	5	5
Under-module complete hydraulic unit	5	6	6	6	6
Insulated flow - return collectors	●	●	●	●	●
Gas duct	●	●	●	●	●
Water and gas connecting pipes	●	●	●	●	●
Flow - return 2-way tap, gas	●	●	●	●	●
Gas tap	●	●	●	●	●
Non-return valve	●	●	●	●	●
High-efficiency - head pump	Self-adj., 12 m	Self-adj., 12 m	Self-adj., 12 m	Self-adj., 12 m	Self-adj., 12 m
Closing flange unit for water and gas collectors	1	1	1	1	1
D 100 extension for boiler - collector flue gas drain connection	5	6	6	6	6
D 100 suction opening	5	6	6	6	6
Flue gas duct D 250	5	6	6	6	6
Connection extension D 250	4	5	5	5	5
D 250 cap for flue gas duct with condensate drain hole	1	1	1	1	1
Cascade collector probe	1	1	1	1	1
Heat transfer paste kit for cascade probe and safety devices on collector	1	1	1	1	1

Reference to images from page 15 on page17

COMBINATION WITH HYDRAULIC SEPARATOR CONSISTING OF THE BASIC COMBINATION WITH DIRECT COLLECTORS WITH THE ADDITION OF THE FOLLOWING COMPONENTS

Models	750	780	810	870	900
Hydraulic separator, with insulation and support with adjustable feet	●	●	●	●	●
Kit of gaskets + screws and nuts for flange connection	●	●	●	●	●
Cascade probe holder	●	●	●	●	●
Automatic bleed on separator	●	●	●	●	●

Reference to images from page 18 on page20

COMBINATION WITH PLATE EXCHANGER CONSISTING OF THE BASIC COMBINATION WITH DIRECT COLLECTORS WITH THE ADDITION OF THE FOLLOWING COMPONENTS

Models	750	780	810	870	900
AISI 304 stainless steel plate exchanger - sized according to power level	●	●	●	●	●
Insulated plate (*) cascade - primary circuit collectors connection kit	●	●	●	●	●
Kit of exchanger support brackets with adjustable feet	●	●	●	●	●
Automatic bleed for collector	●	●	●	●	●
Cascade probe holder	●	●	●	●	●
Kit of gaskets + screws and nuts for flange connection	●	●	●	●	●
Insulated system - plate secondary circuit collectors connection kit	●	●	●	●	●

(*) The collector unit for the connection of the secondary circuit of the plate exchanger according to the right or left position is available as an optional kit
Reference to images from page 21 on page23

Modular generator for indoor installation - with direct collectors, combinations with two boilers in models 45 - 60

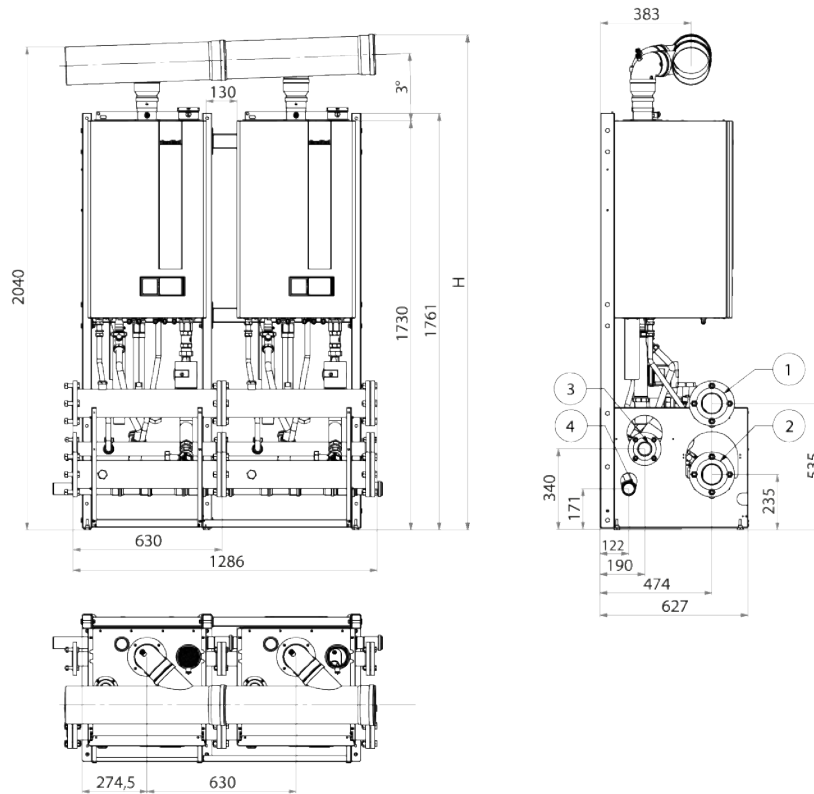

Figure 1: Modular generator with direct collectors

- 1 DN 80 PN 6 flanged primary circuit flow
- 2 DN 80 PN 6 flanged primary circuit return
- 3 DN 50 PN 6 flanged gas inlet
- 4 DN 50 condensate drain

Model	Modules	Safety valve maximum calibration bar	Flue gas vent minimum diameter mm	Flue gas vent height H mm
	Nr (nr x [model])			
45	1 (1 x 45)	3	160	2075
60	1 (1 x 60)	3,5		
90 (**)	2 (2 x 45)	3		2095
105 (**)	2 (1 x 60 + 1 x 45)			

(**) Versions of modular generators offered to create a low power heating system, spread on 2 heat generators instead of 1

Modular generator for indoor installation - with direct collectors, combinations with up to three boilers in models 85 - 120

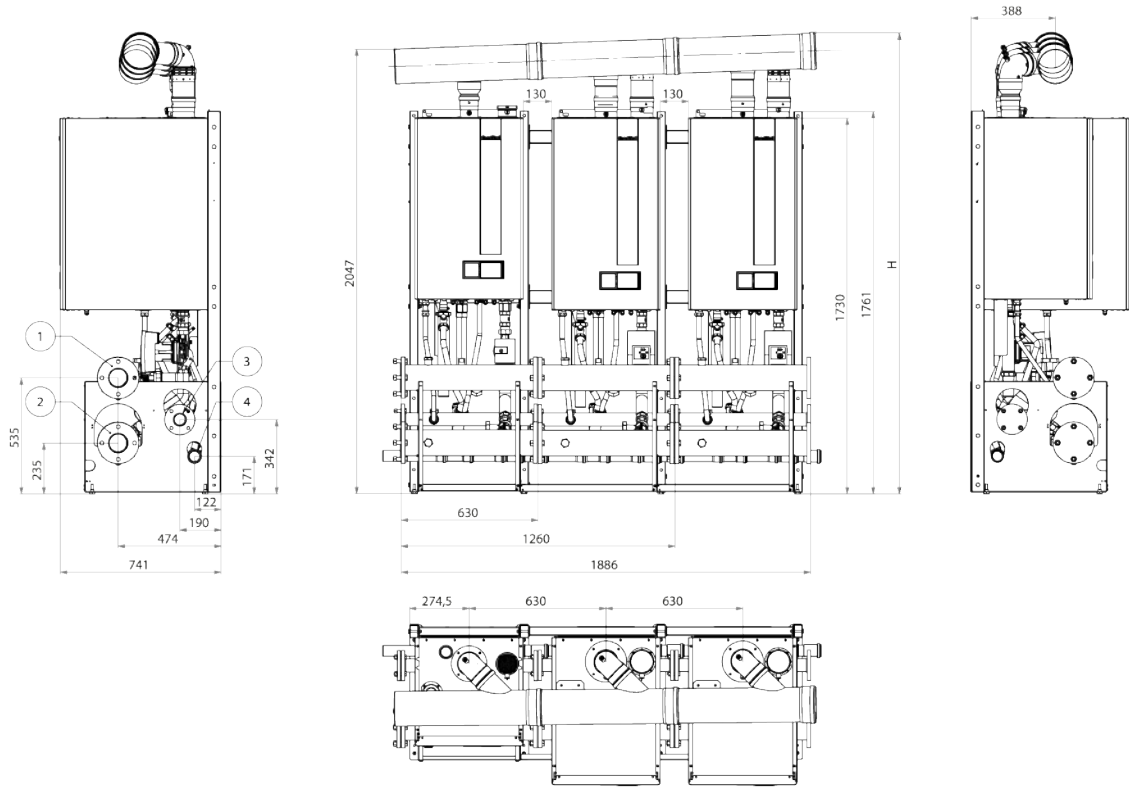

Figure 2: Modular generator with direct collectors

- 1 DN 80 PN 6 flanged primary circuit flow
- 2 DN 80 PN 6 flanged primary circuit return
- 3 DN 50 PN 6 flanged gas inlet
- 4 DN 50 condensate drain

Model	Modules	Safety valve maximum calibration	Flue gas vent minimum diameter	Flue gas vent height H
	Nr (nr x [model])	bar	mm	mm
85	1 (1 x 85)	5	160	2075
120	1 (1 x 120)			2095
170	2 (2 x 85)			
205	2 (1 x 85 + 1 x 120)		2135	
240	2 (2 x 120)			
325	3 (1 x 85 + 2 x 120)	200		

Modular generator for indoor installation - with direct collectors, combinations with up to six boilers in models 120 - 150

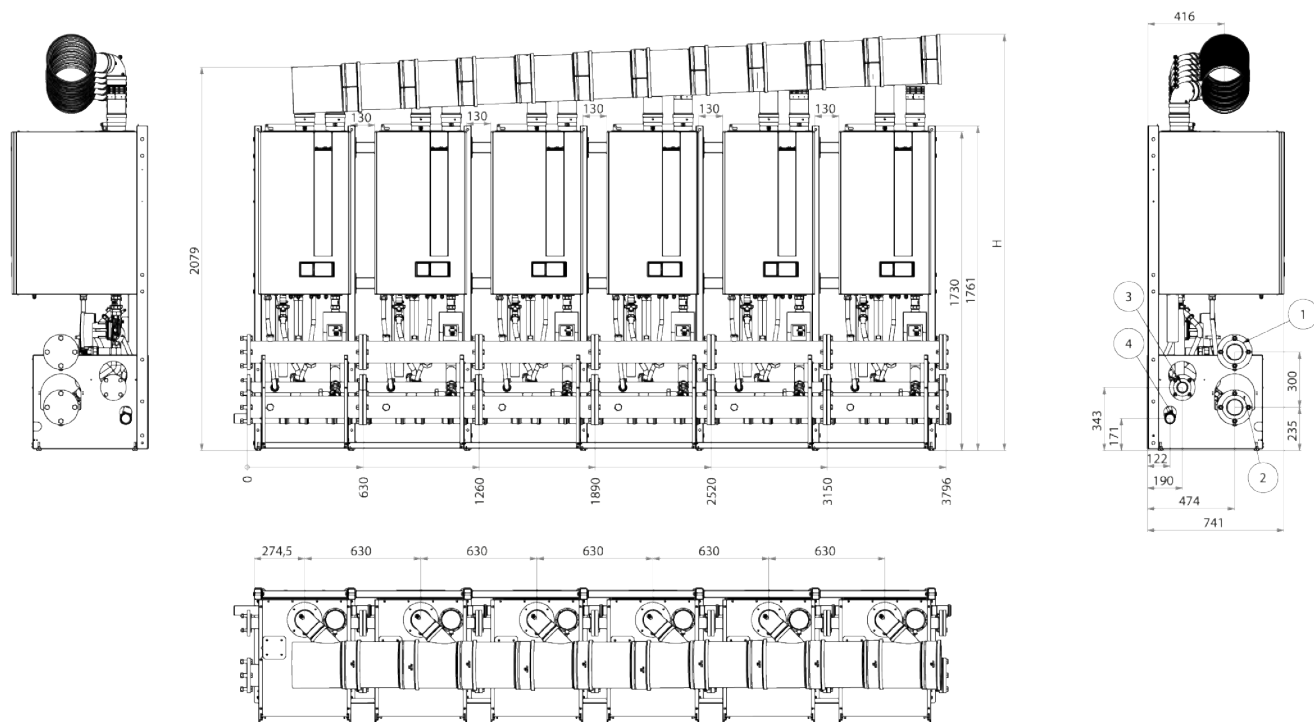

Figure 3: Modular generator with direct collectors

- 1 DN 80 PN 6 flanged primary circuit flow
- 2 DN 80 PN 6 flanged primary circuit return
- 3 DN 50 PN 6 flanged gas inlet
- 4 DN 50 condensate drain

Model	Modules	Safety valve maximum calibration bar	Flue gas vent minimum diameter mm	Flue gas vent height H mm
	Nr (nr x [model])			
150	1 (1 x 150)	5	160	2095
270	2 (1 x 120 + 1 x 150)			
300	2 (2 x 150)			
360	3 (3 x 120)			
390	3 (2 x 120 + 1 x 150)		200	2135
420	3 (1 x 120 + 2 x 150)			
450	3 (3 x 150)			
480	4 (4 x 120)			
510	4 (3 x 120 + 1 x 150)		250	2170
540	4 (2 x 120 + 2 x 150)			
570	4 (1 x 120 + 3 x 150)			
600	4 (4 x 150)			
630	5 (4 x 120 + 1 x 150)	5	250	2230
660	5 (3 x 120 + 2 x 150)			
690	5 (2 x 120 + 3 x 150)			
720	5 (1 x 120 + 4 x 150)			
750	5 (5 x 150)		2260	
780	6 (4 x 120 + 2 x 150)			
810	6 (3x120 + 3 x 150)			
870	6 (1 x 120 + 5 x 150)			
900	6 (6 x 150)			

MODULAR GENERATOR FOR INDOOR INSTALLATION ON FRAME - CONFIGURATION WITH HYDRAULIC SEPARATOR

The modular generator offered in the configuration with hydraulic separator consists of the same modules of the generator with direct collectors with the addition of the "hydraulic separator unit".

Modular generator for indoor installation - with hydraulic separator to the left or to the right, combinations with two boilers in models 45 - 60

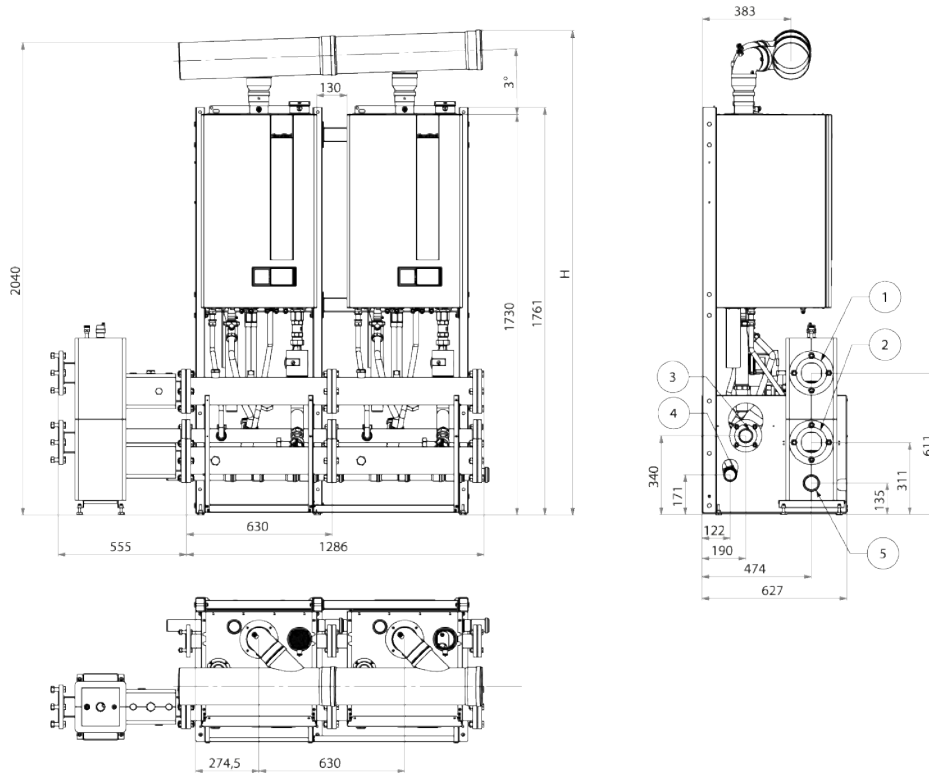

Figure 4: Modular generator with hydraulic separator on the left

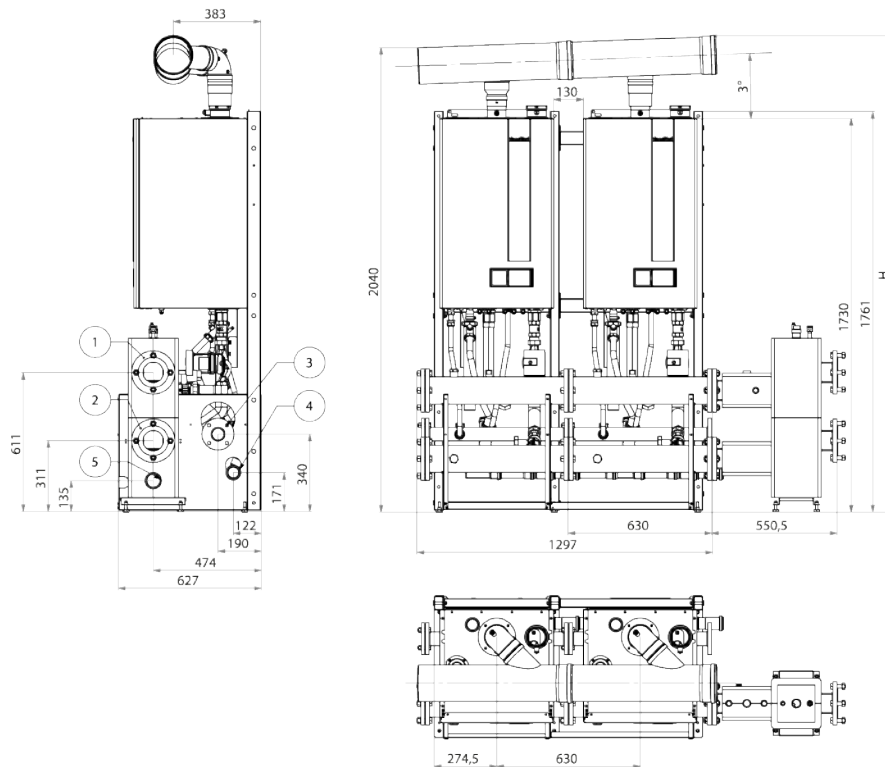

Figure 5: Modular generator with hydraulic separator on the right

- 1 DN 80 PN 6 flanged connection flow
- 2 PN 6 flanged connection return
- 3 DN 50 flanged connection gas inlet
- 4 DN 50 condensate drain
- 5 Circuit breaker drain for the system G 1 ¼ F

Modular generator for indoor installation - with hydraulic separator to the left or to the right, combinations with up to three boilers in models 85 - 120

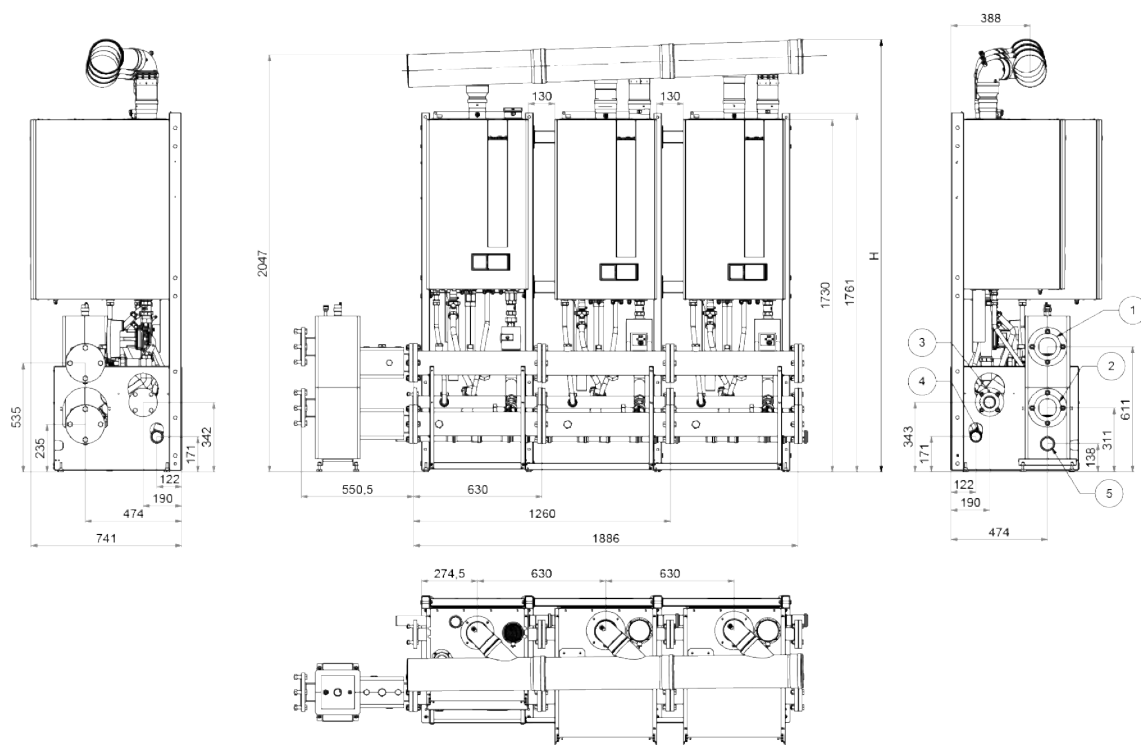

Figure 6: Modular generator with hydraulic separator on the left

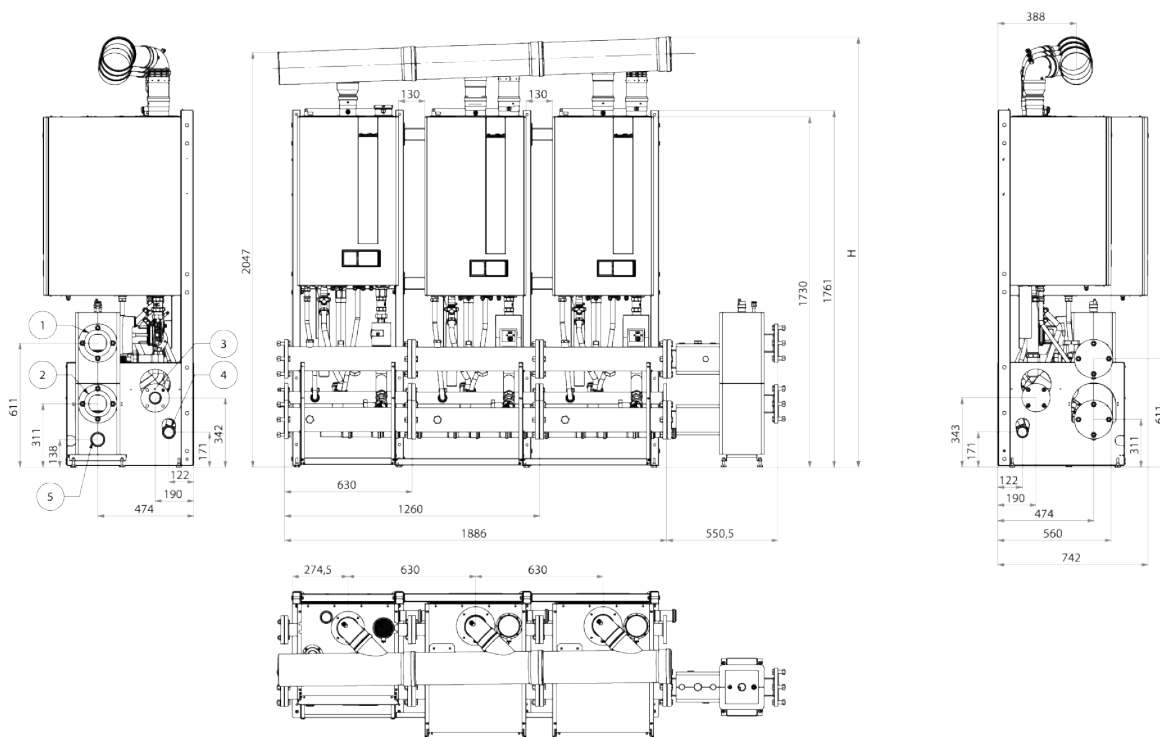

Figure 7: Modular generator with hydraulic separator on the right

- 1 DN 80 PN 6 flanged connection flow
- 2 PN 6 flanged connection return
- 3 DN 50 flanged connection gas inlet
- 4 DN 50 condensate drain
- 5 Circuit breaker drain for the system G 1 ¼ F

Modular generator for indoor installation - with hydraulic separator to the left or to the right, combinations with up to six boilers in models 120 - 150

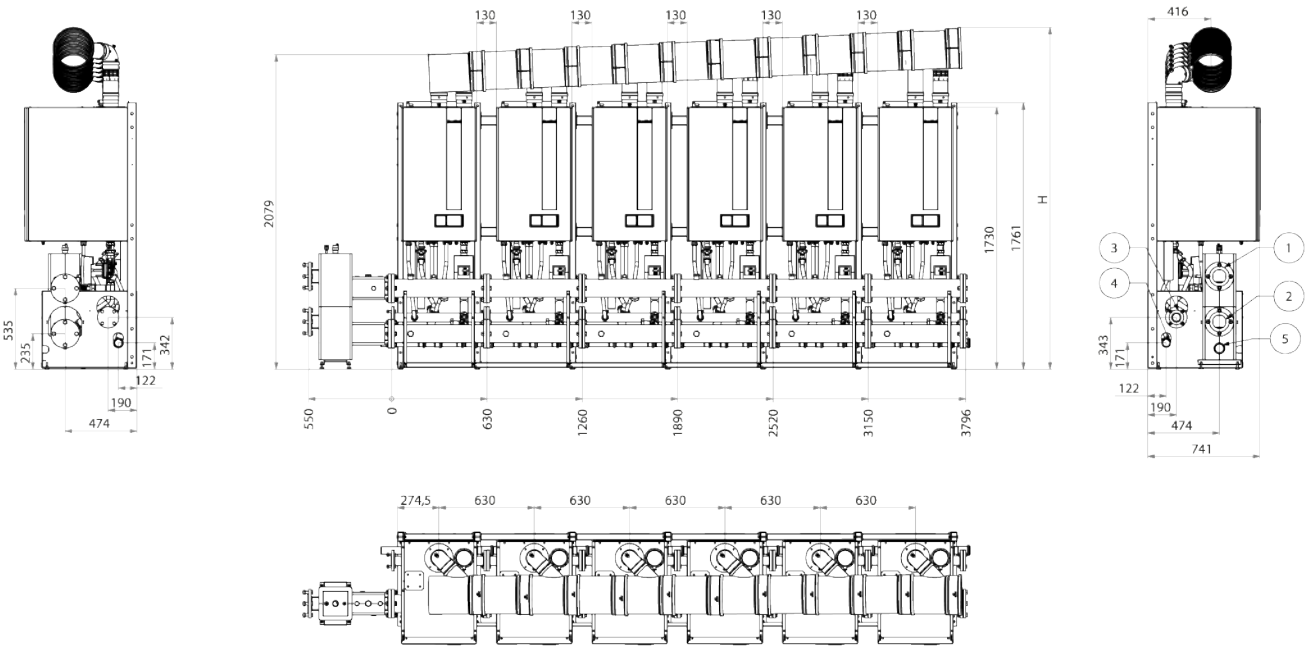

Figure 8: Modular generator with hydraulic separator on the left

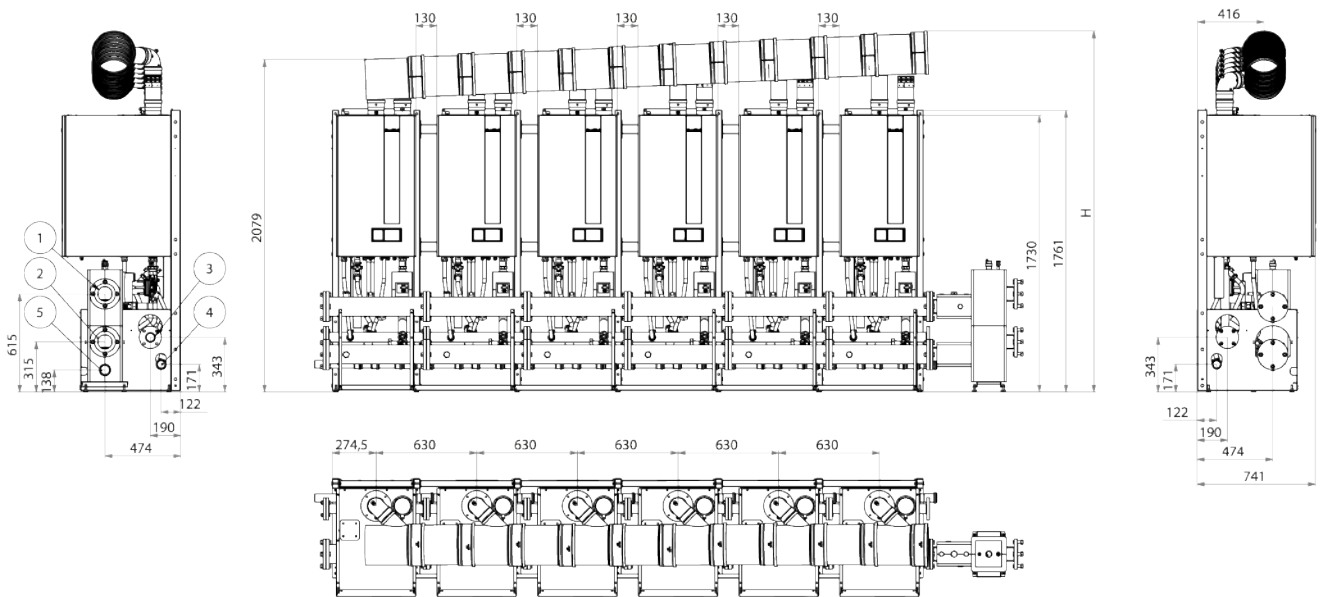

Figure 9: Modular generator with hydraulic separator on the right

- 1 DN 80 PN 6 flanged connection flow
- 2 PN 6 flanged connection return
- 3 DN 50 flanged connection gas inlet
- 4 DN 50 condensate drain
- 5 Circuit breaker drain for the system G 1 ¼ F

MODULAR GENERATOR FOR INDOOR INSTALLATION ON FRAME - CONFIGURATION WITH PLATE EXCHANGER

The modular generator offered in the configuration with plate exchanger consists of the same modules of the generator with direct collectors with the addition of the "plate exchanger unit".

Modular generator for indoor installation - with plate exchanger to the left or to the right, combinations with two boilers in models 45 - 60

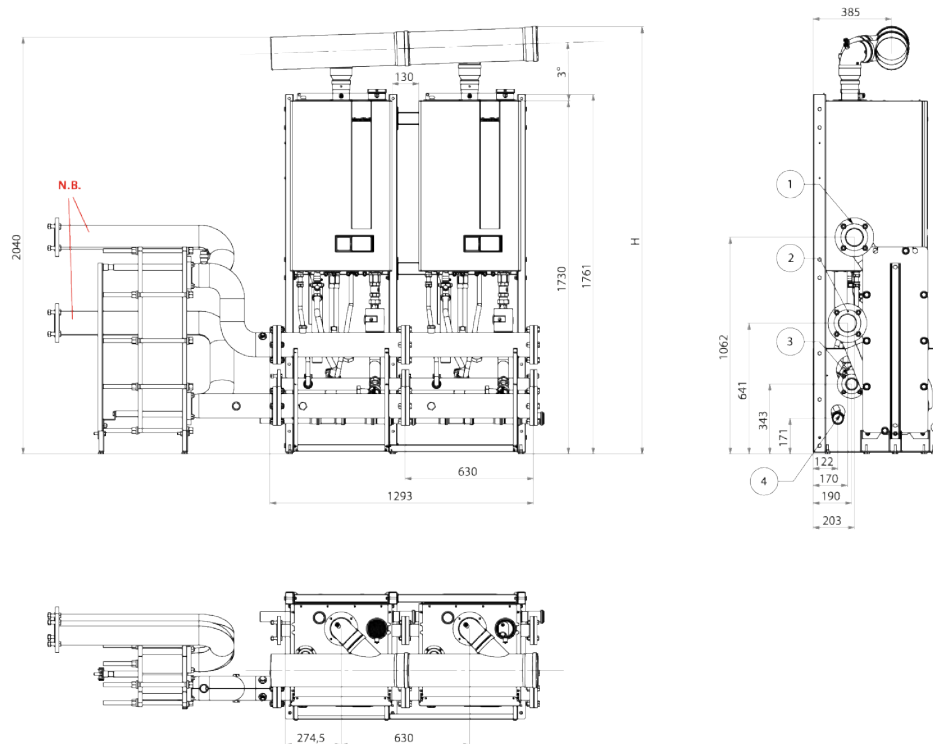

Figure 10: Modular generator with plate exchanger on the left

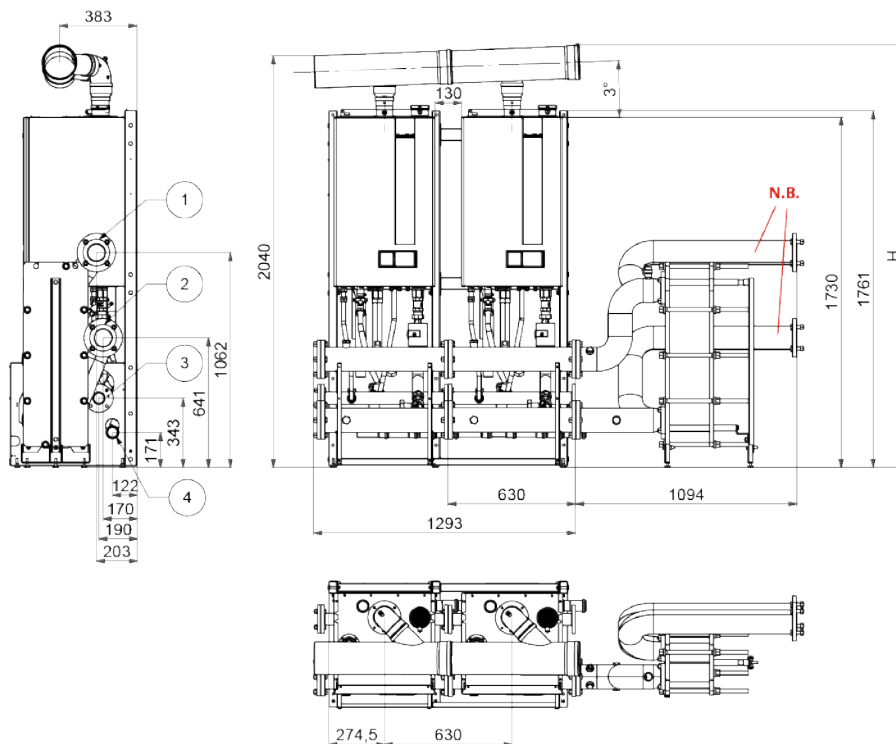

Figure 11: Modular generator with plate exchanger on the right

- 1 DN 80 PN 6 flanged connection flow
- 2 PN 6 flanged connection return
- 3 DN 50 flanged connection gas inlet
- 4 DN 50 condensate drain

N.B. The connecting collector kit for the secondary circuit is optional

Modular generator for indoor installation - with plate exchanger to the left or to the right, combinations with up to three boilers in models 85 - 120

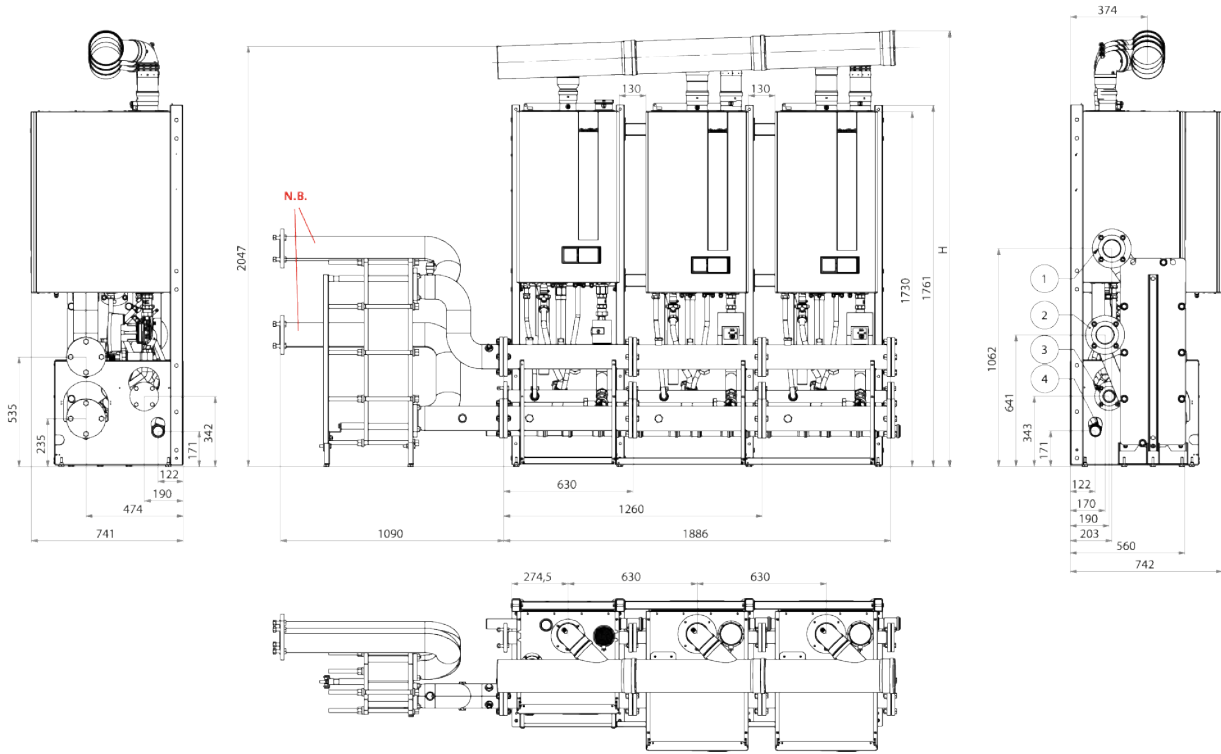

Figure 12: Modular generator with plate exchanger on the left

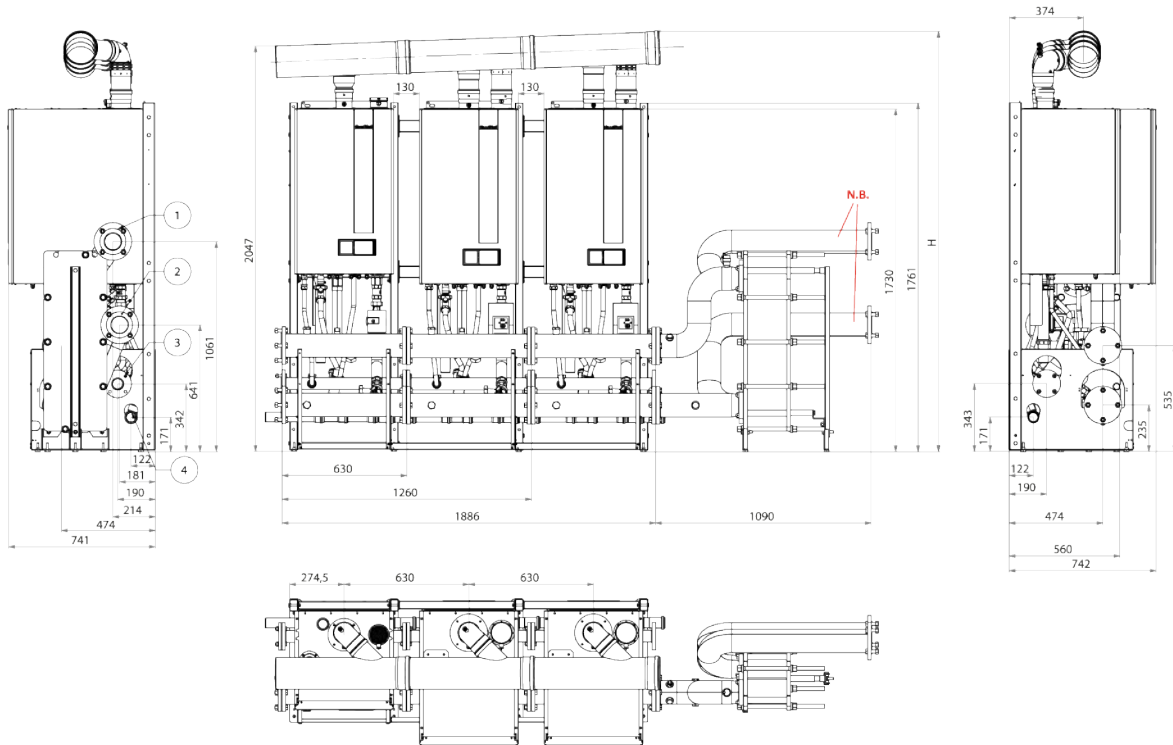

Figure 13: Modular generator with plate exchanger on the right

- 1 DN 80 PN 6 flanged connection flow
- 2 PN 6 flanged connection return
- 3 DN 50 flanged connection gas inlet
- 4 DN 50 condensate drain

N.B. The connecting collector kit for the secondary circuit is optional

Modular generator for indoor installation - with plate exchanger to the left or to the right, combinations with up to six boilers in models 120 - 150

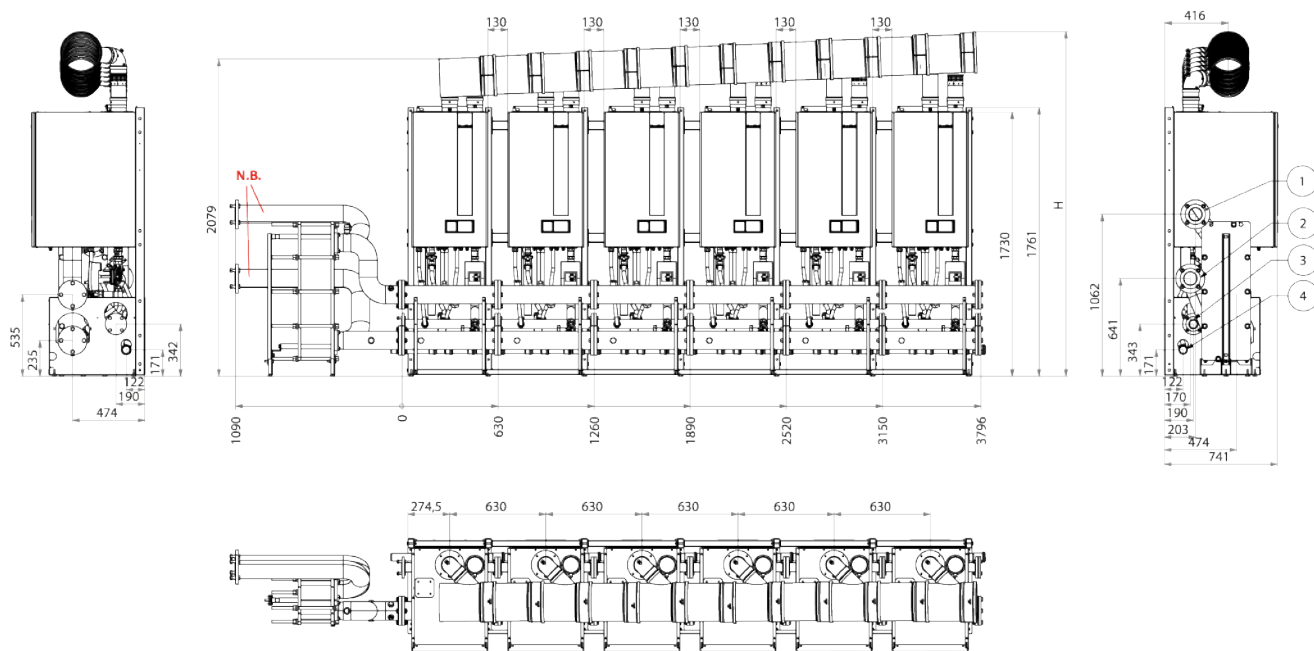

Figure 14: Modular generator with plate exchanger on the left

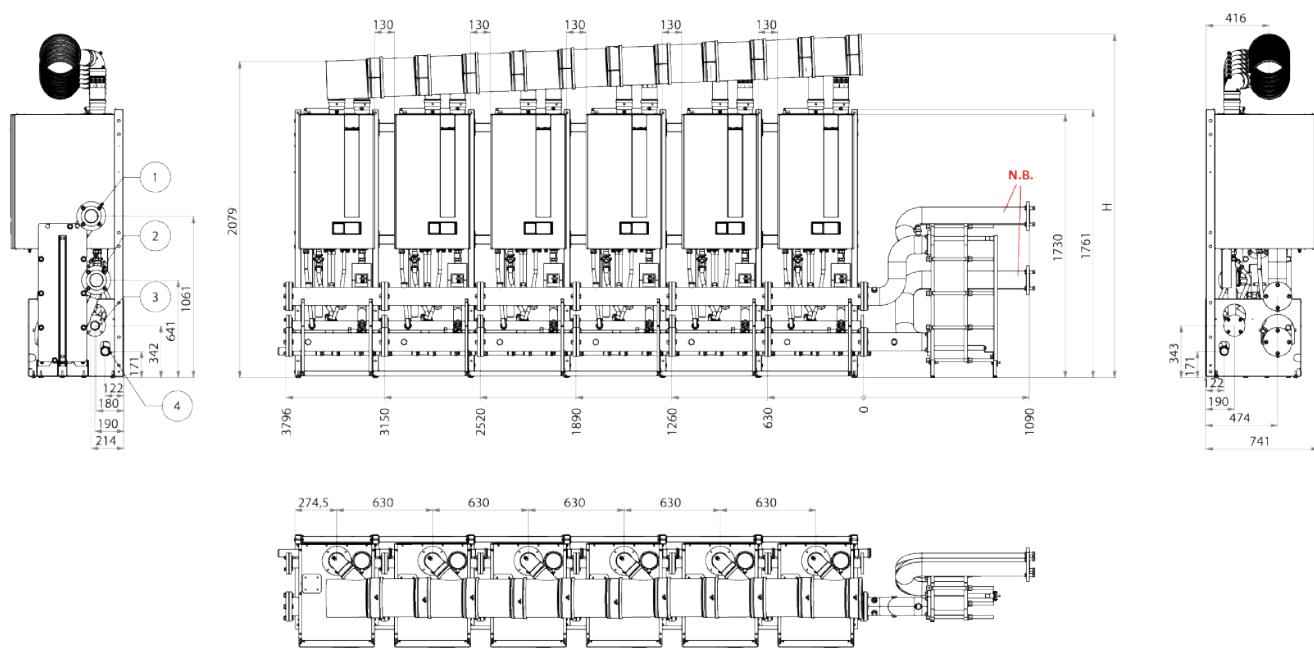

Figure 15: Modular generator with plate exchanger on the right

- 1 DN 80 PN 6 flanged connection flow
- 2 PN 6 flanged connection return
- 3 DN 50 flanged connection gas inlet
- 4 DN 50 condensate drain

N.B. The connecting collector kit for the secondary circuit is optional

ITACA CH KR MODULE

BACK ON BACK

MODULAR CONDENSING HEAT GENERATOR FOR COMMERCIAL HEATING



- › **Multilingual user's interface**
- › **High-efficiency stainless steel heat exchanger**
- › **CH water flow rate double electronic control**
- › **High modulation ratios: for single module up to 1:10; for modular generator up to 1:70**
- › **Integrated cascade management system**
- › **Possibility to combine up to 6 modules (3 in line at the front + 3 in line at the back)**
- › **Integrated flue gas check valve**
- › **Class 6 of NO_x emissions**

Available in the following models:

from **90** to **900**



WARNING

The modular heat generators on supporting frame described in this section of the catalogue must be exclusively installed indoors. The outdoor installation is not included

-) Indoor installations on supporting structure
-) Under-boiler hydraulic unit to be installed with water (insulated) and gas collectors, high-efficiency circulation pump, water and gas connecting ramps
-) Under-boiler hydraulic unit on back side complete with water (with insulation) and gas connection ramps, 2-way flow and return taps, non-return valve, high-efficiency circulation pump
-) Two-way shut-off taps on flow and return
-) Alarm output or LPG valve control, input for external probe, ambient thermostat, hot water storage tank probe, connection for solar pump, plant pump
-) 0-10 V control on temperature or power
-) Cascade management with Master Slave system from boiler control panel
-) Supplied with flue gas duct
-) Total premix, steel, cylindrical burner that can run on several gases
-) Modulating gas valve with constant air/gas ratio
-) Variable speed combustion fan
-) Electrical protection class IPX4D
-) Electronic ignition and ionisation flame detection device
-) Temperature probes checking also the flow rate
-) Flow rate electronic control with flowmeter
-) Available in the following versions: with direct collectors; with hydraulic separator; with plate exchanger

BACK TO BACK MODULAR GENERATOR FOR INDOOR INSTALLATION ON FRAME

Each thermal module of the modular generator consists of the combination of the units described in the tables below. With the exception of the Itaca CH KR heat generators, all the described units must be assembled on site.

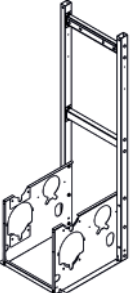
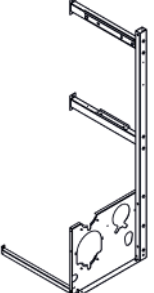
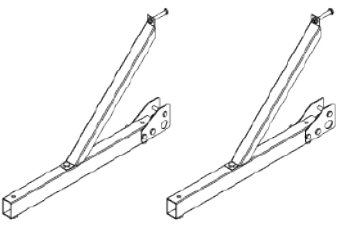
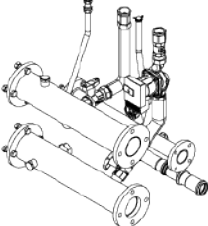
Item	Description
	<p>Heat generator Itaca CH KR in 45 – 60 – 85 – 120 – 150 kW outputs</p>
	<p>Head supporting frame It can be used as a self-supporting frame, to be used for a generator consisting of a single module or as a 'starting' frame for the series of generators.</p>
	<p>"Expansion" supporting frame To be used to add a maximum of 5 modules in series to the head supporting frame, for a maximum total number of 6 modules.</p>
	<p>Frame support bracket kit for back-to-back version 1 kit consists of two sets of brackets, to be assembled on the external sides of the load-bearing structure</p>
	<p>Under-boiler hydraulic unit - front side consisting of:</p> <ul style="list-style-type: none"> - Flanged DN 80 PN 6 insulated flow - return collectors - DN 50 PN 6 flanged gas duct - Non-return valve - High efficiency circulation pump - Gas connecting pipes - Hydraulic connecting pipes - Two-way tap for return and flow collector - Discharge pipes

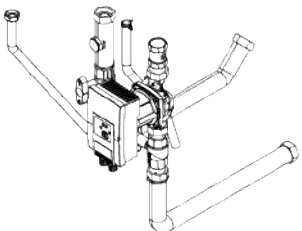
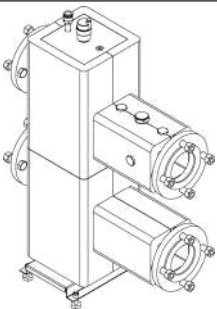
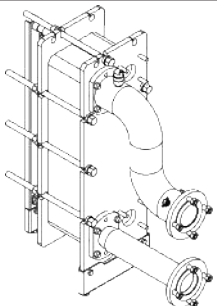

Item	Description
	<p>Under-boiler hydraulic unit - back side Preset to be assembled under every boiler installed on cascade back side. consisting of:</p> <ul style="list-style-type: none"> - High-efficiency pump - Non-return valve - Two-way tap for return and flow collector - Gas tap - Water and gas pipes for the connection to the water and gas collectors of the front side cascade
	<p>Hydraulic separator unit valid for all outputs up to 900 Kw</p>
	<p>Plate exchanger unit with collectors Available in 10 models to be matched to the offered modular generator output levels, it also features the connecting collectors between primary circuit and plates</p>

The modular generator is offered in the following configurations

Configuration with modular generator	
Direct collectors	Modular generator connected to the primary circuit without separating device in the hydraulic circuit (*)
With hydraulic separator	Modular generator with connection to the primary circuit, provided with hydraulic separator for the separation of the primary and secondary circuit
With plate exchanger	Modular generator with connection to the primary circuit, provided with plate exchanger for the separation of the primary and secondary circuit

(*) It is mandatory to combine a hydraulic separator or a plate exchanger to separate the primary circuit (cascade side) from the secondary circuit (plant side)

The modular generator is supplied with the following combinations of heating modules:

Model	Modules Nr (nr x [model])	Front - back arrangement (n front side) + (m back side)	Model	Modules Nr (nr x [model])	Front - back arrangement (n front side) + (m back side)
90	2 (2 x 45)	1 + 1	360	3 (3 x 120)	2 + 1
120	2 (2 x 60)	1 + 1	390	3 (2 x 120 + 1 x 150)	2 + 1
145	2 (1 x 60 + 1 x 85)	1 + 1	450	3 (3 x 150)	2 + 1
170	2 (2 x 85)	1 + 1	480	4 (4 x 120)	2 + 2
180	3 (3 x 60)	2 + 1	540	4 (2 x 120 + 2 x 150)	2 + 2
205	3 (2 x 60 + 1 x 85)	2 + 1	600	4 (4 x 150)	2 + 2
240	2 (2 x 120)	1 + 1	660	5 (3 x 120 + 2 x 150)	3 + 2
255	3 (3 x 85)	2 + 1	750	5 (5 x 150)	3 + 2
270	2 (1 x 120 + 1 x 150)	1 + 1	810	6 (3 x 120 + 3 x 150)	3 + 3
300	2 (2 x 150)	1 + 1	900	6 (6 x 150)	3 + 3

BACK TO BACK MODULAR GENERATOR FOR INDOOR INSTALLATION ON FRAME - SYSTEM CONFIGURATION DESCRIPTION

The modular generator in "back to back" installation mainly consists of a line of cascade-connected boilers on "front side" and a line of cascade-connected boilers on "back side" up to a maximum of 3 heat generators per side.

The cascade-installed boilers on "front side" are characterised by an under-boiler hydraulic unit featuring the main water and gas collectors.

The cascade-installed boilers on "back side" are characterised by an under-boiler hydraulic unit not featuring the main water and gas collectors, but instead the water and gas connecting ramps between boiler and system main collectors ("front side").

As for the possibility of installation and the number of modules, the following diagram shows the number of boilers installed on the "front side" **n** + the number of boilers installed on the "back side" **m**, (**n+m**).

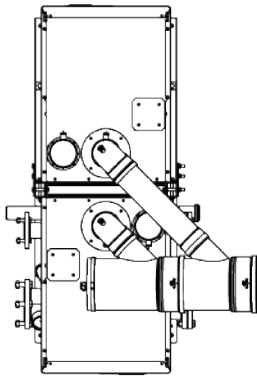

Configuration 1+1

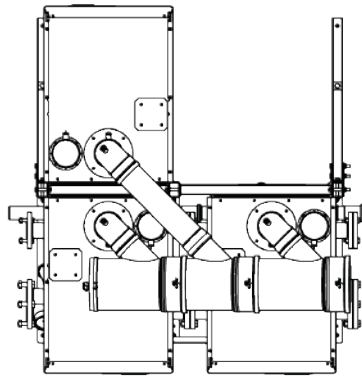

Configuration 2+1

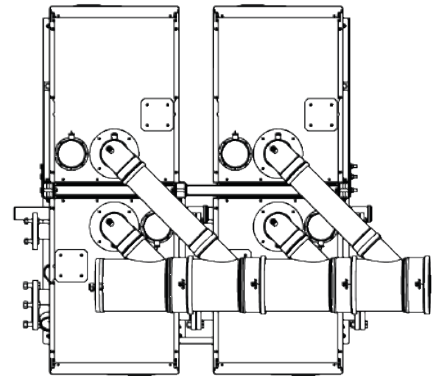

Configuration 2+2

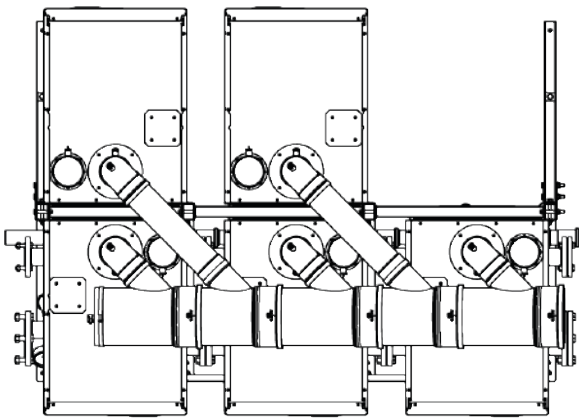

Configuration 3+2

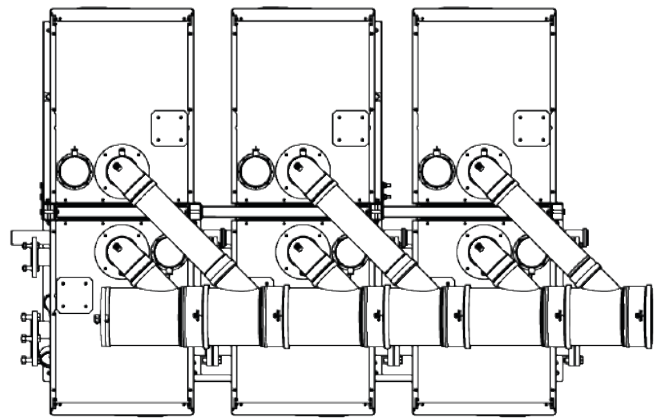

Configuration 3+3

NOTE: ($n + m$) where n = number of boilers installed on the front side and m = number of boilers installed on the back side

PRODUCT CONFIGURATION

BASIC COMBINATION WITH DIRECT COLLECTORS

Models	90	120	145	170	180
Itaca CH KR 45 heat generator	2	-	-	-	-
Itaca CH KR 60 heat generator	-	2	1	-	3
Itaca CH KR 85 heat generator	-	-	1	2	-
Front - back arrangement	1 + 1	1 + 1	1 + 1	1 + 1	2 + 1
Support / start frame	1	1	1	1	1
Expansion frame	-	-	-	-	1
Under-module complete hydraulic unit - front side	1	1	1	1	2
Under-module complete hydraulic unit - back side	1	1	1	1	1
Insulated return / flow collectors + gas collector	●	●	●	●	●
Water and gas connecting pipes	●	●	●	●	●
Flow - return 2-way tap, gas	●	●	●	●	●
Gas Tap	●	●	●	●	●
Non-return valve	●	●	●	●	●
High-efficiency - head pump	PWM - 7.5 m	PWM - 8 m	PWM - 11 m	PWM - 11 m	PWM - 8 m
Closing flange unit for water and gas collectors	1	1	1	1	1
Flue gas duct D 200	2	2	2	2	3
D 100 extension for boiler - collector flue gas drain connection	2	2	2	2	3
D 80 - 100 adapter for flue gas duct	2	2	2	2	3
D 100 L 500 extension for boiler - collector flue gas drain connection - back side	1	1	1	1	1
D 80 air suction opening	2	2	2	2	3
D 200 cap for flue gas duct with condensate drain hole	1	1	1	1	1
Cascade collector probe	1	1	1	1	1
Heat transfer paste kit for cascade probe and safety devices on collector	1	1	1	1	1

Reference to images from page 32

**COMBINATION WITH HYDRAULIC SEPARATOR
CONSISTING OF THE BASIC COMBINATION WITH DIRECT COLLECTORS WITH THE ADDITION OF THE FOLLOWING COMPONENTS**

Models	90	120	145	170	180
Hydraulic separator, with insulation	●	●	●	●	●
Kit of gaskets + screws and nuts for flange connection	●	●	●	●	●
Cascade probe holder	●	●	●	●	●
Automatic bleed on separator	●	●	●	●	●

Reference to images from page 33

**COMBINATION WITH PLATE EXCHANGER
CONSISTING OF THE BASIC COMBINATION WITH DIRECT COLLECTORS WITH THE ADDITION OF THE FOLLOWING COMPONENTS**

Models	90	120	145	170	180
AISI 304 stainless steel plate exchanger - sized according to power level	●	●	●	●	●
Insulated plate (*) cascade - primary circuit collectors connection kit	●	●	●	●	●
Kit of exchanger support brackets with adjustable feet	●	●	●	●	●
Automatic bleed for collector	●	●	●	●	●
Cascade probe holder	●	●	●	●	●
Kit of gaskets + screws and nuts for flange connection	●	●	●	●	●

(*) The collector unit for the connection of the secondary circuit of the plate exchanger according to the right or left position is available as an optional kit
Reference to images from page 34

BASIC COMBINATION WITH DIRECT COLLECTORS

Models	205	240	255	270	300
Itaca CH KR 60 heat generator	2	-	-	-	-
Itaca CH KR 85 heat generator	1	-	3	-	-
Itaca CH KR 120 heat generator	-	2	-	1	-
Itaca CH KR 150 heat generator	-	-	-	1	2
Front - back arrangement	2 + 1	1 + 1	2 + 1	1 + 1	1 + 1
Support / start frame	1	1	1	1	1
Expansion frame	1	-	1	-	-
Under-module complete hydraulic unit - front side	2	1	2	1	1
Under-module complete hydraulic unit - back side	1	-	-	-	-
Insulated return / flow collectors + gas collector	●	●	●	●	●
Water and gas connecting pipes	●	●	●	●	●
Flow - return 2-way tap, gas	●	●	●	●	●
Gas Tap	●	●	●	●	●
Non-return valve	●	●	●	●	●
High-efficiency - head pump	PWM - 8 m PWM - 11 m	Self-adj., 12 m	PWM - 11 m	Self-adj., 12 m	Self-adj., 12 m
Closing flange unit for water and gas collectors	1	1	1	1	1
Flue gas duct D 200	3	2	3	2	2
D 100 extension for boiler - collector flue gas drain connection	3	2	3	2	2
D 80 - 100 adapter for flue gas duct	3	-	3	-	-
D 100 L 500 extension for boiler - collector flue gas drain connection - back side	1	1	1	1	1
D 80 air suction opening	3	-	3	-	-
D 100 suction opening	-	2	-	2	2
D 200 cap for flue gas duct with condensate drain hole	1	1	1	1	1
Cascade collector probe	1	1	1	1	1
Heat transfer paste kit for cascade probe and safety devices on collector	1	1	1	1	1

Reference to images from page 32

COMBINATION WITH HYDRAULIC SEPARATOR CONSISTING OF THE BASIC COMBINATION WITH DIRECT COLLECTORS WITH THE ADDITION OF THE FOLLOWING COMPONENTS

Models	205	240	255	270	300
Hydraulic separator, with insulation	●	●	●	●	●
Kit of gaskets + screws and nuts for flange connection	●	●	●	●	●
Cascade probe holder	●	●	●	●	●
Automatic bleed on separator	●	●	●	●	●

Reference to images from page 33

COMBINATION WITH PLATE EXCHANGER CONSISTING OF THE BASIC COMBINATION WITH DIRECT COLLECTORS WITH THE ADDITION OF THE FOLLOWING COMPONENTS

Models	205	240	255	270	300
AISI 304 stainless steel plate exchanger - sized according to power level	●	●	●	●	●
Insulated plate (*) cascade - primary circuit collectors connection kit	●	●	●	●	●
Kit of exchanger support brackets with adjustable feet	●	●	●	●	●
Automatic bleed for collector	●	●	●	●	●
Cascade probe holder	●	●	●	●	●
Kit of gaskets + screws and nuts for flange connection	●	●	●	●	●

(*) The collector unit for the connection of the secondary circuit of the plate exchanger according to the right or left position is available as an optional kit
Reference to images from page 34

BASIC COMBINATION WITH DIRECT COLLECTORS

Models	360	390	450	480	540
Itaca CH KR 120 heat generator	3	2	-	4	2
Itaca CH KR 150 heat generator	-	1	3	-	2
Front - back arrangement	2 + 1	2 + 1	2 + 1	2 + 2	2 + 2
Support / start frame	1	1	1	1	1
Expansion frame	1	-	1	1	1
Under-module complete hydraulic unit - front side	2	2	2	2	2
Under-module complete hydraulic unit - back side	-	-	1	2	2
Insulated return / flow collectors + gas collector	●	●	●	●	●
Water and gas connecting pipes	●	●	●	●	●
Flow - return 2-way tap, gas	●	●	●	●	●
Gas Tap	●	●	●	●	●
Non-return valve	●	●	●	●	●
High-efficiency - head pump	Self-adj., 12 m	Self-adj., 12 m	Self-adj., 12 m	Self-adj., 12 m	Self-adj., 12 m
Closing flange unit for water and gas collectors	1	1	1	1	1
Flue gas duct D 200	3	3	3	4	4
D 100 extension for boiler - collector flue gas drain connection	3	3	3	4	4
D 100 L 500 extension for boiler - collector flue gas drain connection - back side	1	1	1	2	2
D 100 suction opening	3	3	3	4	4
D 200 cap for flue gas duct with condensate drain hole	1	1	1	1	1
Cascade collector probe	1	1	1	1	1
Heat transfer paste kit for cascade probe and safety devices on collector	1	1	1	1	1

Reference to images from page 32

COMBINATION WITH HYDRAULIC SEPARATOR CONSISTING OF THE BASIC COMBINATION WITH DIRECT COLLECTORS WITH THE ADDITION OF THE FOLLOWING COMPONENTS

Models	360	390	450	480	540
Hydraulic separator, with insulation	●	●	●	●	●
Kit of gaskets + screws and nuts for flange connection	●	●	●	●	●
Cascade probe holder	●	●	●	●	●
Automatic bleed on separator	●	●	●	●	●

Reference to images from page 33

COMBINATION WITH PLATE EXCHANGER CONSISTING OF THE BASIC COMBINATION WITH DIRECT COLLECTORS WITH THE ADDITION OF THE FOLLOWING COMPONENTS

Models	360	390	450	480	540
AISI 304 stainless steel plate exchanger - sized according to power level	●	●	●	●	●
Insulated plate (*) cascade - primary circuit collectors connection kit	●	●	●	●	●
Kit of exchanger support brackets with adjustable feet	●	●	●	●	●
Automatic bleed for collector	●	●	●	●	●
Cascade probe holder	●	●	●	●	●
Kit of gaskets + screws and nuts for flange connection	●	●	●	●	●

(*) The collector unit for the connection of the secondary circuit of the plate exchanger according to the right or left position is available as an optional kit
Reference to images from page 34

BASIC COMBINATION WITH DIRECT COLLECTORS					
Models	600	660	750	810	900
Itaca CH KR 120 heat generator	-	3	-	3	-
Itaca CH KR 150 heat generator	4	2	5	3	6
Front - back arrangement	2 + 2	3 + 2	3 + 2	3 + 3	3 + 3
Support / start frame	1	1	1	1	1
Expansion frame	1	2	2	2	2
Under-module complete hydraulic unit - front side	2	3	3	3	3
Under-module complete hydraulic unit - back side	2	2	2	3	3
Insulated return / flow collectors + gas collector	●	●	●	●	●
Water and gas connecting pipes	●	●	●	●	●
Flow - return 2-way tap, gas	●	●	●	●	●
Gas Tap	●	●	●	●	●
Non-return valve	●	●	●	●	●
High-efficiency - head pump	Self-adj., 12 m	Self-adj., 12 m	Self-adj., 12 m	Self-adj., 12 m	Self-adj., 12 m
Closing flange unit for water and gas collectors	1	1	1	1	1
Flue gas duct D 200	4	-	-	-	-
Flue gas duct D 250	-	5	5	6	6
D 100 extension for boiler - collector flue gas drain connection	4	5	5	6	6
D 100 L 500 extension for boiler - collector flue gas drain connection - back side	2	2	2	3	3
D 100 suction opening	4	5	5	6	6
D 200 cap for flue gas duct with condensate drain hole	1	-	-	-	-
D 250 cap for flue gas duct with condensate drain hole	-	1	1	1	1
Cascade collector probe	1	1	1	1	1
Heat transfer paste kit for cascade probe and safety devices on collector	1	1	1	1	1

Reference to images from page 32

COMBINATION WITH HYDRAULIC SEPARATOR CONSISTING OF THE BASIC COMBINATION WITH DIRECT COLLECTORS WITH THE ADDITION OF THE FOLLOWING COMPONENTS					
Models	600	660	750	810	900
Hydraulic separator, with insulation	●	●	●	●	●
Kit of gaskets + screws and nuts for flange connection	●	●	●	●	●
Cascade probe holder	●	●	●	●	●
Automatic bleed on separator	●	●	●	●	●

Reference to images from page 33

COMBINATION WITH PLATE EXCHANGER CONSISTING OF THE BASIC COMBINATION WITH DIRECT COLLECTORS WITH THE ADDITION OF THE FOLLOWING COMPONENTS					
Models	600	660	750	810	900
AISI 304 stainless steel plate exchanger - sized according to power level	●	●	●	●	●
Insulated plate (*) cascade - primary circuit collectors connection kit	●	●	●	●	●
Kit of exchanger support brackets with adjustable feet	●	●	●	●	●
Automatic bleed for collector	●	●	●	●	●
Cascade probe holder	●	●	●	●	●
Kit of gaskets + screws and nuts for flange connection	●	●	●	●	●

(*) The collector unit for the connection of the secondary circuit of the plate exchanger according to the right or left position is available as an optional kit
Reference to images from page 34

Back to back modular generator for indoor installation - with direct collectors

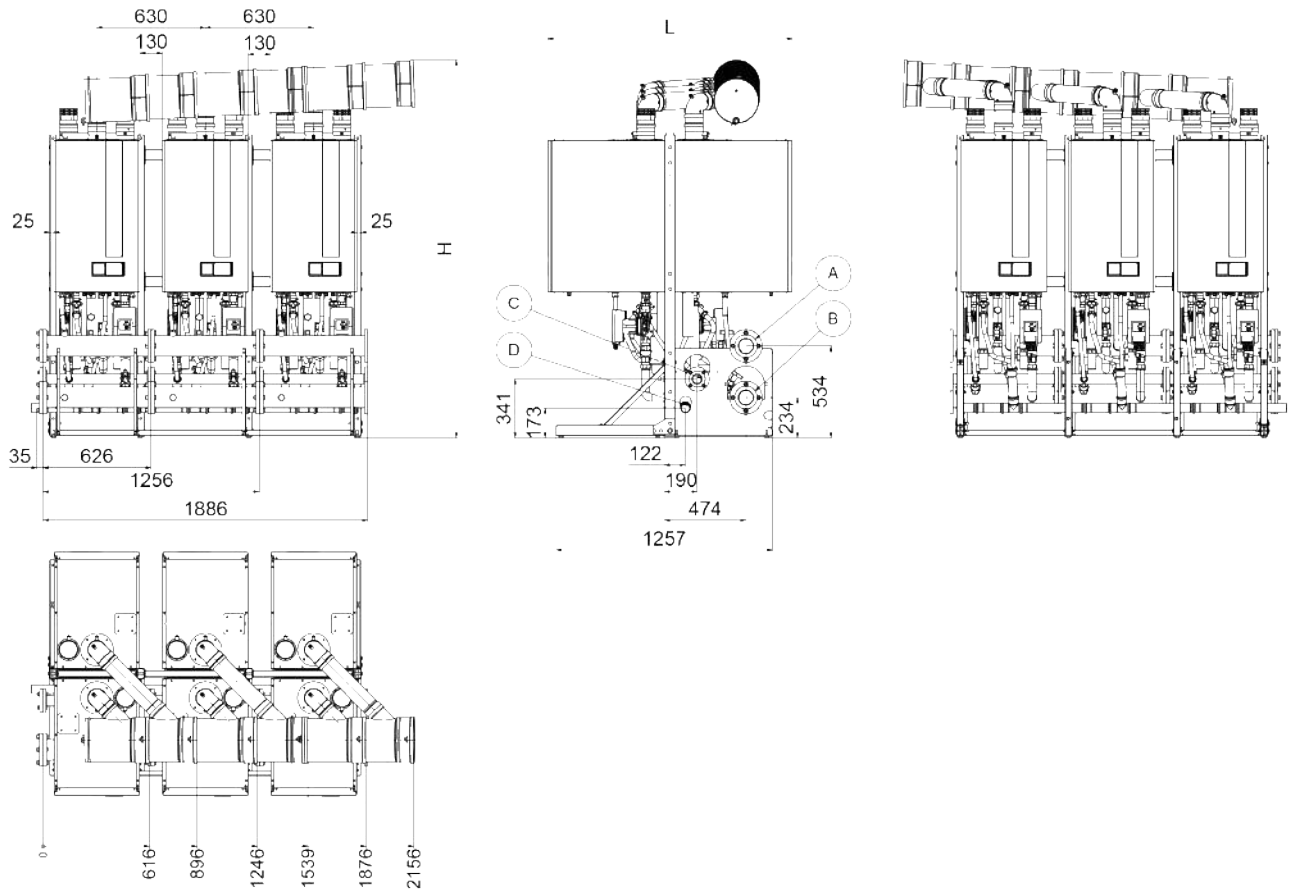

Figure 16: Back to back modular generator with direct collectors

- A DN 80 Pn6 flanged primary circuit flow
- B DN 80 Pn6 flanged primary circuit return
- C DN 50 Pn6 flanged gas inlet
- D DN 50 condensate drain

Model	Modules	Front - back arrangement (n front side) + (m back side)	Safety valve maximum calibration	TMS	Dimension L	Dimension H	Flue gas vent minimum diameter					
	Nr (nr x [model])		bar	°C	mm	mm						
90	2 (2 x 45)	1 + 1	3	110	2200	2200	200					
120	2 (2 x 60)		3,5									
145	2 (1 x 60 + 1 x 85)		5									
170	2 (2 x 85)		3,5									
180	3 (3 x 60)	2 + 1	5		2210	2210						
205	3 (2 x 60 + 1 x 85)				2120	2120						
240	2 (2 x 120)				2220	2220						
255	3 (3 x 85)	2 + 1	5		2120	2120		200				
270	2 (1 x 120 + 1 x 150)	1 + 1							2130	2130		
300	2 (2 x 150)											
360	3 (3 x 120)	2 + 1									2150	2150
390	3 (2 x 120 + 1 x 150)											
450	3 (3 x 150)											
480	4 (4 x 120)											
540	4 (2 x 120 + 2 x 150)	2 + 2		2180	2180							
600	4 (4 x 150)											
660	5 (3 x 120 + 2 x 150)	3 + 2		2190	2190	250						
750	5 (5 x 150)											
810	6 (3 x 120 + 3 x 150)	3 + 3	2190	2190	250							
900	6 (6 x 150)											

BACK TO BACK MODULAR GENERATOR FOR INDOOR INSTALLATION ON FRAME - CONFIGURATION WITH HYDRAULIC SEPARATOR

The modular generator offered in the configuration with hydraulic separator consists of the same modules of the generator with direct collectors with the addition of the "hydraulic separator unit".

Back to back modular generator for indoor installation - with hydraulic separator

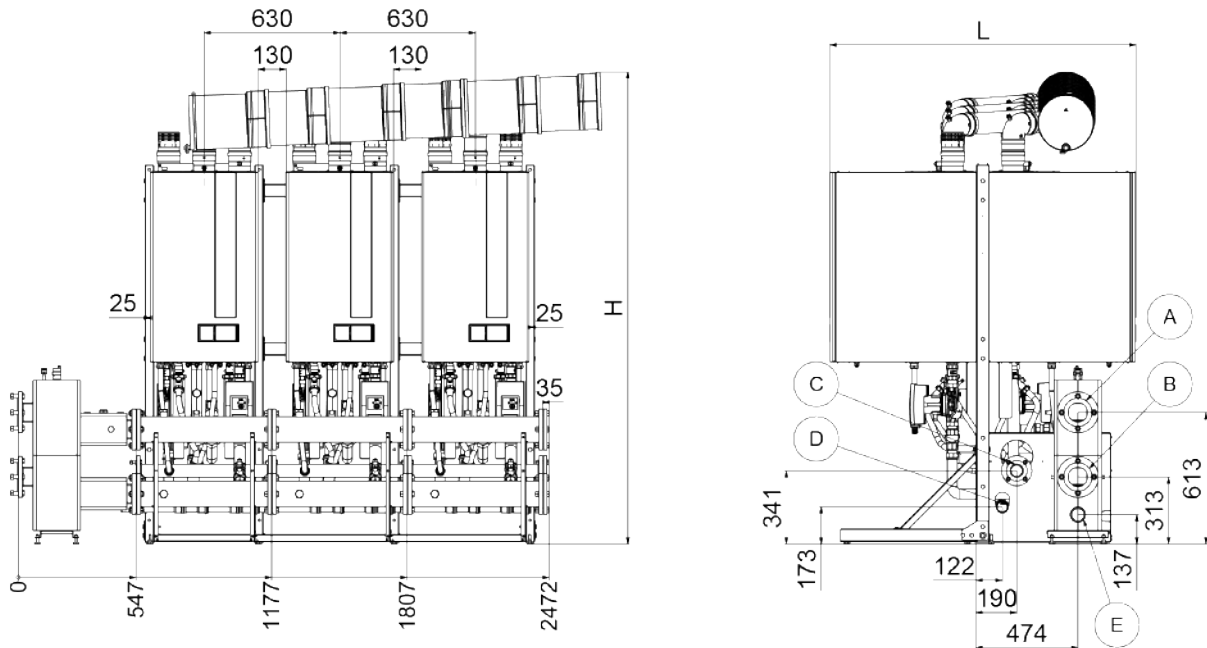

Figure 17: Back to back modular generator with hydraulic separator on the left

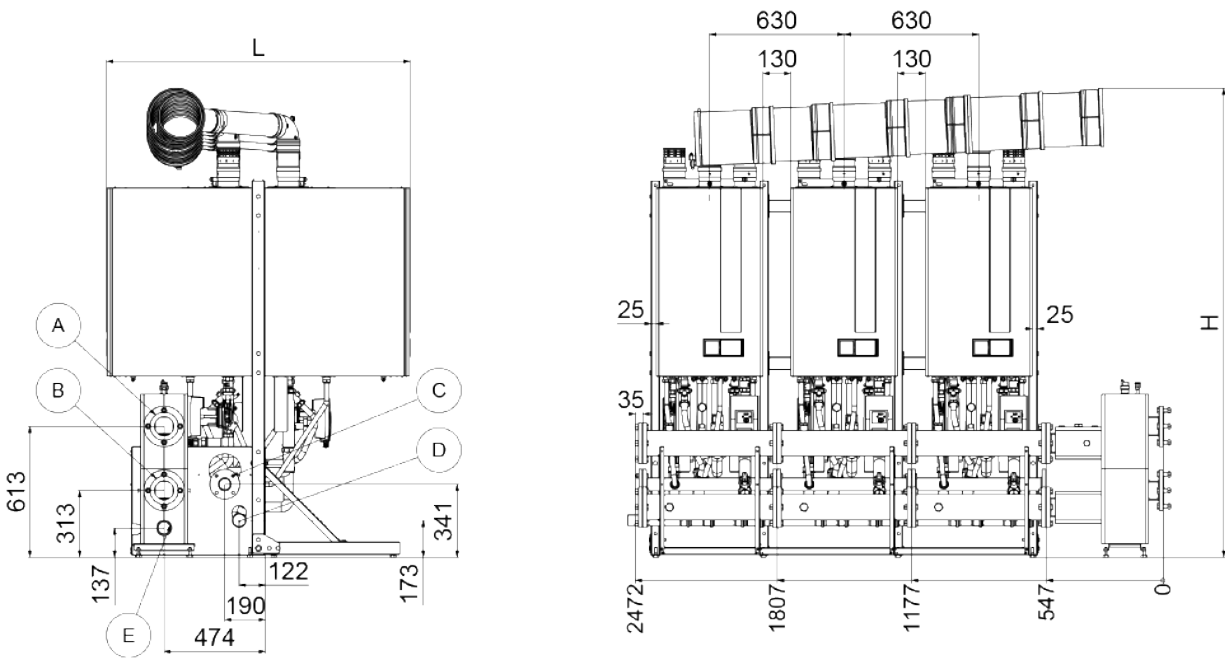

Figure 18: Back to back modular generator with hydraulic separator on the right

- A** DN 80 Pn6 flanged primary circuit flow
- B** DN 80 Pn6 flanged primary circuit return
- C** DN 50 Pn6 flanged gas inlet
- D** DN 50 condensate drain
- E** Circuit breaker drain for the system G 1 ¼ F

BACK TO BACK MODULAR GENERATOR FOR INDOOR INSTALLATION ON FRAME - CONFIGURATION WITH PLATE EXCHANGER

The modular generator offered in the configuration with plate exchanger consists of the same modules of the generator with direct collectors with the addition of the "plate exchanger unit".

Back to back modular generator for indoor installation - with plate exchanger

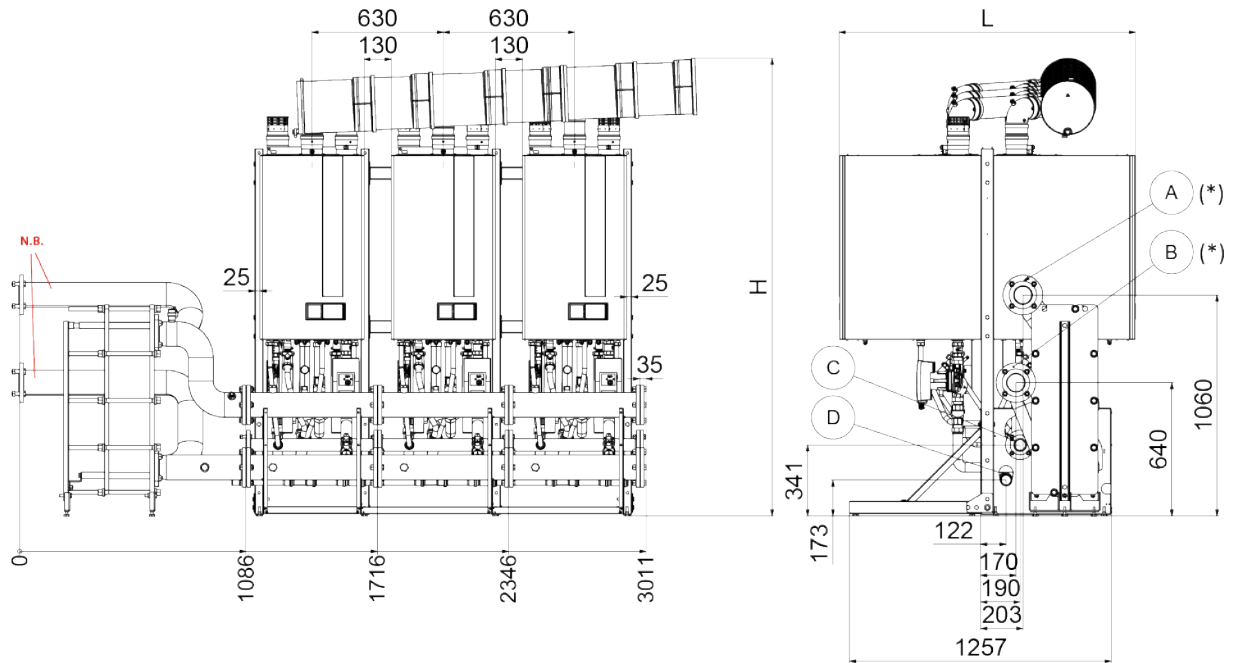

Figure 19: Back to back modular generator with plate exchanger on the left

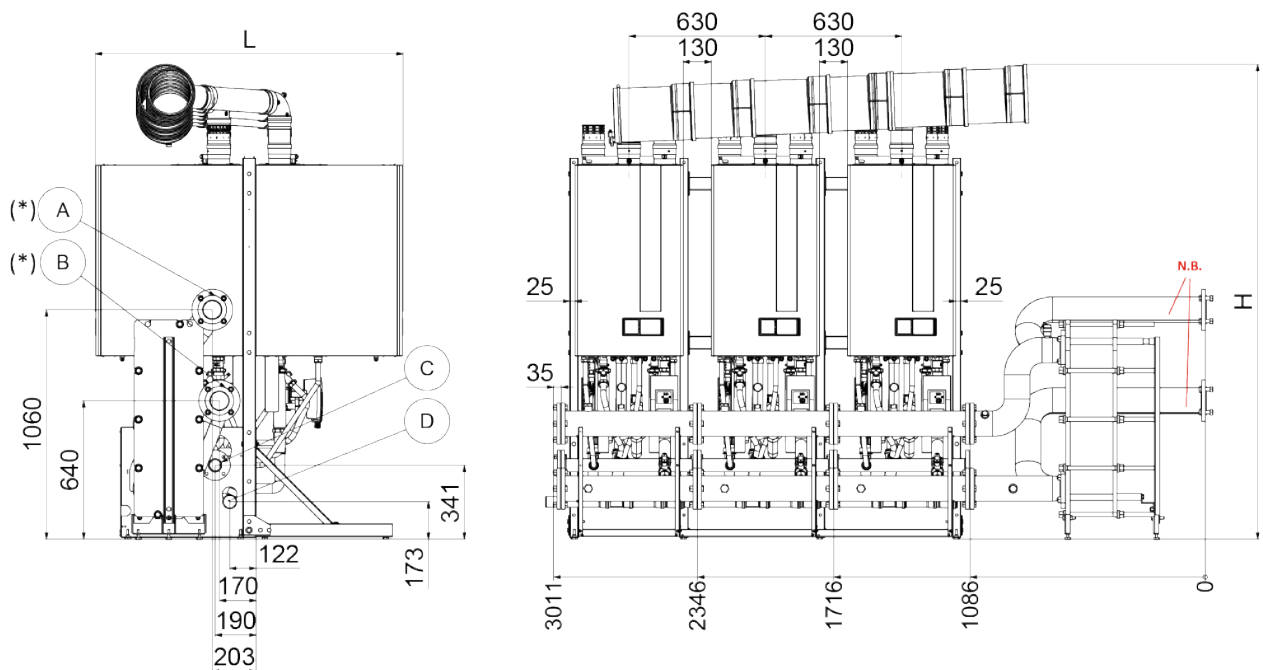

Figure 20: Back to back modular generator with plate exchanger on the right

- A** DN 80 Pn6 flanged primary circuit flow
- B** DN 80 Pn6 flanged primary circuit return
- C** DN 50 Pn6 flanged gas inlet
- D** DN 50 condensate drain

N.B. The connecting collector kit for the secondary circuit is optional



ITACA CH KR CABINET MODULE

MODULAR CONDENSING HEAT GENERATOR FOR COMMERCIAL HEATING



- › Polyester powder coated steel cabinet for outdoor installation
- › Multilingual user's interface
- › High-efficiency stainless steel heat exchanger
- › CH water flow rate double electronic control
- › High modulation ratios: for single module up to 1:10; for modular generator up to 1:70
- › Integrated cascade management system
- › Possibility to connect up to 6 boilers in a cascade-type connection
- › Integrated flue gas check valve
- › Class 6 of NOx emissions

The declared efficiency class is not requested for output models above 70 kW.

Available in the following models:

from **45** to **900**

-) Under-boiler hydraulic unit to be installed with water (insulated) and gas collectors, high-efficiency circulation pump, water and gas connecting ramps, expansion vessel
-) Two-way shut-off taps on flow and return
-) Alarm output or LPG valve control, input for external probe, ambient thermostat, hot water storage tank probe, connection for solar pump, plant pump
-) 0-10 V control on temperature or power
-) Cascade management with Master Slave system from boiler control panel
-) Total premix, steel, cylindrical burner that can run on several gases
-) Modulating gas valve with constant air/gas ratio
-) Variable speed combustion fan
-) Electronic ignition and ionisation flame detection device
-) Temperature probes checking also the flow rate
-) Flow rate electronic control with flowmeter
-) Electrical protection class IPX5D
-) Available in the following versions: with direct collectors; with hydraulic separator; with plate exchanger

MODULAR GENERATOR FOR OUTDOOR INSTALLATION INSIDE CABINET

The modular generators for outdoor installation are configured by the combination of modules that must be positioned and assembled together by means of screws and gaskets between one module and the next one, since there is no closing panel between the sides of two adjacent modules. The modules that can be combined together are:

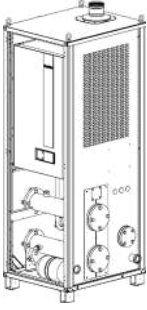
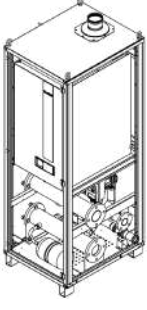
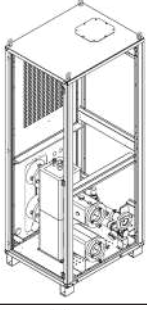
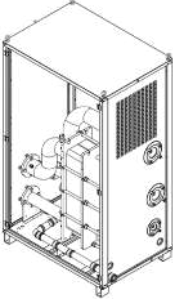
Item	Description
	<p>"Head" module 45 - 60 - 85 - 120 - 150 kW Assembled in a cabinet with door painted structure, for outdoor installation. Including: Heat generator Complete hydraulic unit</p> <ul style="list-style-type: none"> - Insulated flow - return collectors - Gas duct - High efficiency pump - Expansion vessel - Collector - heat generator connecting taps and pipes - Gas Tap - Non-return valve - Condensate drain system <p>The head module is available in the "right" and "left" versions, matched with an external side panel assembled to the right or to the left, respectively.</p>
	<p>"Expansion" module Assembled in a cabinet with door painted structure, for outdoor installation. Including: Heat generator Complete hydraulic unit</p> <ul style="list-style-type: none"> - Insulated flow - return collectors - Gas duct - High efficiency pump - Expansion vessel - Collector - heat generator connecting taps and pipes - Gas Tap - Non-return valve - Condensate drain system <p>The expansion module does not feature side closing panels since it must be positioned between the two head modules that start and close the series.</p>
	<p>Module with separator Assembled in a cabinet with door painted structure, for outdoor installation. Including:</p> <ul style="list-style-type: none"> - Hydraulic separator - Gas ducts - Cascade management probe <p>The module with separator is available in the right and left versions, since it has to be positioned at the beginning of the series; it is therefore equipped with a side closing panel on the right or on the left, respectively.</p>
	<p>Module with plate exchanger Assembled in a painted structure, for outdoor installation. Including:</p> <ul style="list-style-type: none"> - Plate exchanger (10 models matched to output levels) - Gas ducts - Primary circuit and plate connecting collectors (insulated) - Secondary circuit plate connecting collectors (insulated) <p>The module with exchanger is available in the right and left versions, since it has to be positioned at the beginning of the series; it is therefore equipped with a side closing panel on the right or on the left, respectively.</p>

NOTE: only the modules to be connected at the ends of the cascade feature side closing panels

The modular generator is offered in the following configurations

Configuration with modular generator	
Direct collectors	Modular generator connected to the primary circuit without separating device in the hydraulic circuit (*)
With hydraulic separator	Modular generator with connection to the primary circuit, provided with hydraulic separator for the separation of the primary and secondary circuit
With plate exchanger	Modular generator with connection to the primary circuit, provided with plate exchanger for the separation of the primary and secondary circuit

(*) It is mandatory to combine a hydraulic separator or a plate exchanger to separate the primary circuit (cascade side) from the secondary circuit (plant side)

The modular generator is supplied with the following combinations of heating modules:

Model	Modules	Model	Modules
	Nr (nr x [model])		Nr (nr x [model])
45	1 (1 x 45)	450	3 (3 x 150)
60	1 (1 x 60)	480	4 (4 x 120)
85	1 (1 x 85)	510	4 (3 x 120 + 1 x 150)
90 (**)	2 (2 x 45)	540	4 (2 x 120 + 2 x 150)
105 (**)	2 (1 x 60 + 1 x 45)	570	4 (1 x 120 + 3 x 150)
120	1 (1 x 120)	600	4 (4 x 150)
150	1 (1 x 150)	630	5 (4 x 120 + 1 x 150)
170	2 (2 x 85)	660	5 (3 x 120 + 2 x 150)
205	2 (1 x 85 + 1 x 120)	690	5 (2 x 120 + 3 x 150)
240	2 (2 x 120)	720	5 (1 x 120 + 4 x 150)
270	2 (1 x 120 + 1 x 150)	750	5 (5 x 150)
300	2 (2 x 150)	780	6 (4 x 120 + 2 x 150)
325	3 (1 x 85 + 2 x 120)	810	6 (3x120 + 3 x 150)
360	3 (3 x 120)	870	6 (1 x 120 + 5 x 150)
390	3 (2 x 120 + 1 x 150)	900	6 (6 x 150)
420	3 (1 x 120 + 2 x 150)		

(**) Versions of modular generators offered to create a low power heating system, spread on 2 heat generators instead of 1

PRODUCT CONFIGURATION

All combinations of modular generators are intended as pre-assembled modules to be assembled together in-line.

Each module inside cabinet is equipped with height adjustable feet.

In the combinations with direct collectors, a module with hydraulic separator or plate exchanger must be installed in order to separate the primary circuit from the secondary circuit.

BASIC COMBINATION WITH DIRECT COLLECTORS				
Models	45	60	90 (**)	105 (**)
Itaca CH KR 45 heat generator	1	-	2	1
Itaca CH KR 60 heat generator	-	1	-	1
Under-module complete hydraulic unit	1	1	2	2
Insulated flow - return collectors	●	●	●	●
Gas duct	●	●	●	●
Water and gas connecting pipes	●	●	●	●
Flow - return 2-way tap, gas	●	●	●	●
Gas tap	●	●	●	●
Non-return valve	●	●	●	●
High-efficiency - head pump	PWM - 7.5 m	PWM - 8 m	PWM - 7.5 m	PWM - 8 m
Expansion tank 5l	1	1	1	1
Closing flange unit for water and gas collectors	1	1	1	1
Cascade collector probe	1	1	1	1
Heat transfer paste kit for cascade probe and safety devices on collector	1	1	1	1

(**) Versions of modular generators offered to create a low power heating system, spread on 2 heat generators instead of 1

Reference to images from page 47 on page49

COMBINATION WITH HYDRAULIC SEPARATOR CONSISTING OF THE BASIC COMBINATION WITH DIRECT COLLECTORS WITH THE ADDITION OF THE FOLLOWING COMPONENTS				
Models	45	60	90 (**)	105 (**)
Hydraulic separator, with insulation	●	●	●	●
Kit of gaskets + screws and nuts for flange connection	●	●	●	●
Cascade probe holder	●	●	●	●
Automatic bleed on separator	●	●	●	●

WHEN SELECTING THE COMBINATION, SPECIFY WHETHER THE MODULE WITH HYDRAULIC SEPARATOR WILL BE INSTALLED TO THE LEFT OR TO THE RIGHT OF THE CASCADE, THE POSITION REFERS TO THE FRONT VIEW

(**) Versions of modular generators offered to create a low power heating system, spread on 2 heat generators instead of 1

Reference to images from page 50 on page52

COMBINATION WITH PLATE EXCHANGER CONSISTING OF THE BASIC COMBINATION WITH DIRECT COLLECTORS WITH THE ADDITION OF THE FOLLOWING COMPONENTS				
Models	45	60	90 (**)	105 (**)
AISI 304 stainless steel plate exchanger - sized according to power level	●	●	●	●
Insulated plate cascade - primary circuit collectors connection kit	●	●	●	●
Insulated system - plate secondary circuit collectors connection kit	●	●	●	●
Kit of gaskets + screws and nuts for flange connection	●	●	●	●
Automatic bleed for collector	●	●	●	●
Cascade probe holder	●	●	●	●

WHEN SELECTING THE COMBINATION, SPECIFY WHETHER THE MODULE WITH PLATE EXCHANGER WILL BE INSTALLED TO THE LEFT OR TO THE RIGHT OF THE CASCADE, THE POSITION REFERS TO THE FRONT VIEW

(**) Versions of modular generators offered to create a low power heating system, spread on 2 heat generators instead of 1

Reference to images from page 53 on page55

All combinations of modular generators are intended as pre-assembled modules to be assembled together in-line.

Each module inside cabinet is equipped with height adjustable feet.

In the combinations with direct collectors, a module with hydraulic separator or plate exchanger must be installed in order to separate the primary circuit from the secondary circuit.

BASIC COMBINATION WITH DIRECT COLLECTORS			
Models	85	120	170
Itaca CH KR 85 heat generator	1	-	2
Itaca CH KR 120 heat generator	-	1	-
Under-module complete hydraulic unit	1	1	2
Insulated flow - return collectors	●	●	●
Gas duct	●	●	●
Water and gas connecting pipes	●	●	●
Flow - return 2-way tap, gas	●	●	●
Gas tap	●	●	●
Non-return valve	●	●	●
High-efficiency - head pump	PWM - 11 m	Self-adj., 12 m	PWM - 11 m
Expansion tank 5l	1	1	1
Closing flange unit for water and gas collectors	1	1	1
Cascade collector probe	1	1	1
Heat transfer paste kit for cascade probe and safety devices on collector	1	1	1

Reference to images from page 47 on page49

COMBINATION WITH HYDRAULIC SEPARATOR CONSISTING OF THE BASIC COMBINATION WITH DIRECT COLLECTORS WITH THE ADDITION OF THE FOLLOWING COMPONENTS			
Models	85	120	170
Hydraulic separator, with insulation	●	●	●
Kit of gaskets + screws and nuts for flange connection	●	●	●
Cascade probe holder	●	●	●
Automatic bleed on separator	●	●	●

WHEN SELECTING THE COMBINATION, SPECIFY WHETHER THE MODULE WITH HYDRAULIC SEPARATOR WILL BE INSTALLED TO THE LEFT OR TO THE RIGHT OF THE CASCADE, THE POSITION REFERS TO THE FRONT VIEW

Reference to images from page 50 on page52

COMBINATION WITH PLATE EXCHANGER CONSISTING OF THE BASIC COMBINATION WITH DIRECT COLLECTORS WITH THE ADDITION OF THE FOLLOWING COMPONENTS			
Models	85	120	170
AISI 304 stainless steel plate exchanger - sized according to power level	●	●	●
Insulated plate cascade - primary circuit collectors connection kit	●	●	●
Insulated system - plate secondary circuit collectors connection kit	●	●	●
Kit of gaskets + screws and nuts for flange connection	●	●	●
Automatic bleed for collector	●	●	●
Cascade probe holder	●	●	●

WHEN SELECTING THE COMBINATION, SPECIFY WHETHER THE MODULE WITH PLATE EXCHANGER WILL BE INSTALLED TO THE LEFT OR TO THE RIGHT OF THE CASCADE, THE POSITION REFERS TO THE FRONT VIEW

Reference to images from page 53 on page55

All combinations of modular generators are intended as pre-assembled modules to be assembled together in-line.

Each module inside cabinet is equipped with height adjustable feet.

In the combinations with direct collectors, a module with hydraulic separator or plate exchanger must be installed in order to separate the primary circuit from the secondary circuit.

BASIC COMBINATION WITH DIRECT COLLECTORS			
Models	205	240	325
Itaca CH KR 85 heat generator	1	-	1
Itaca CH KR 120 heat generator	1	2	2
Under-module complete hydraulic unit	2	2	3
Insulated flow - return collectors	●	●	●
Gas duct	●	●	●
Water and gas connecting pipes	●	●	●
Flow - return 2-way tap, gas	●	●	●
Gas tap	●	●	●
Non-return valve	●	●	●
High-efficiency - head pump	PWM - 11 m Self-adj., 12 m (*)	Self-adj., 12 m	PWM - 11 m Self-adj., 12 m (*)
Expansion tank 5l	1	1	1
Closing flange unit for water and gas collectors	1	1	1
Cascade collector probe	1	1	1
Heat transfer paste kit for cascade probe and safety devices on collector	1	1	1

(*) The PWM 11 m pump is matched with the hydraulic unit with 85 kW heat generator

Reference to images from page 47 on page49

COMBINATION WITH HYDRAULIC SEPARATOR CONSISTING OF THE BASIC COMBINATION WITH DIRECT COLLECTORS WITH THE ADDITION OF THE FOLLOWING COMPONENTS			
Models	205	240	325
Hydraulic separator, with insulation	●	●	●
Kit of gaskets + screws and nuts for flange connection	●	●	●
Cascade probe holder	●	●	●
Automatic bleed on separator	●	●	●

WHEN SELECTING THE COMBINATION, SPECIFY WHETHER THE MODULE WITH HYDRAULIC SEPARATOR WILL BE INSTALLED TO THE LEFT OR TO THE RIGHT OF THE CASCADE, THE POSITION REFERS TO THE FRONT VIEW

Reference to images from page 50 on page52

COMBINATION WITH PLATE EXCHANGER CONSISTING OF THE BASIC COMBINATION WITH DIRECT COLLECTORS WITH THE ADDITION OF THE FOLLOWING COMPONENTS			
Models	205	240	325
AISI 304 stainless steel plate exchanger - sized according to power level	●	●	●
Insulated plate cascade - primary circuit collectors connection kit	●	●	●
Insulated system - plate secondary circuit collectors connection kit	●	●	●
Kit of gaskets + screws and nuts for flange connection	●	●	●
Automatic bleed for collector	●	●	●
Cascade probe holder	●	●	●

WHEN SELECTING THE COMBINATION, SPECIFY WHETHER THE MODULE WITH PLATE EXCHANGER WILL BE INSTALLED TO THE LEFT OR TO THE RIGHT OF THE CASCADE, THE POSITION REFERS TO THE FRONT VIEW

Reference to images from page 53 on page55

All combinations of modular generators are intended as pre-assembled modules to be assembled together in-line.

Each module inside cabinet is equipped with height adjustable feet.

In the combinations with direct collectors, a module with hydraulic separator or plate exchanger must be installed in order to separate the primary circuit from the secondary circuit.

BASIC COMBINATION WITH DIRECT COLLECTORS				
Models	150	270	300	360
Itaca CH KR 120 heat generator	-	1	-	3
Itaca CH KR 150 heat generator	1	1	2	-
Under-module complete hydraulic unit	1	2	2	3
Insulated flow - return collectors	●	●	●	●
Gas duct	●	●	●	●
Water and gas connecting pipes	●	●	●	●
Flow - return 2-way tap, gas	●	●	●	●
Gas tap	●	●	●	●
Non-return valve	●	●	●	●
High-efficiency - head pump	Self-adj., 12 m	Self-adj., 12 m	Self-adj., 12 m	Self-adj., 12 m
Expansion tank 5l	1	1	1	1
Closing flange unit for water and gas collectors	1	1	1	1
Cascade collector probe	1	1	1	1
Heat transfer paste kit for cascade probe and safety devices on collector	1	1	1	1

Reference to images from page 47 on page49

COMBINATION WITH HYDRAULIC SEPARATOR CONSISTING OF THE BASIC COMBINATION WITH DIRECT COLLECTORS WITH THE ADDITION OF THE FOLLOWING COMPONENTS				
Models	150	270	300	360
Hydraulic separator, with insulation	●	●	●	●
Kit of gaskets + screws and nuts for flange connection	●	●	●	●
Cascade probe holder	●	●	●	●
Automatic bleed on separator	●	●	●	●

WHEN SELECTING THE COMBINATION, SPECIFY WHETHER THE MODULE WITH HYDRAULIC SEPARATOR WILL BE INSTALLED TO THE LEFT OR TO THE RIGHT OF THE CASCADE, THE POSITION REFERS TO THE FRONT VIEW

Reference to images from page 50 on page52

COMBINATION WITH PLATE EXCHANGER CONSISTING OF THE BASIC COMBINATION WITH DIRECT COLLECTORS WITH THE ADDITION OF THE FOLLOWING COMPONENTS				
Models	150	270	300	360
AISI 304 stainless steel plate exchanger - sized according to power level	●	●	●	●
Insulated plate cascade - primary circuit collectors connection kit	●	●	●	●
Insulated system - plate secondary circuit collectors connection kit	●	●	●	●
Kit of gaskets + screws and nuts for flange connection	●	●	●	●
Automatic bleed for collector	●	●	●	●
Cascade probe holder	●	●	●	●

WHEN SELECTING THE COMBINATION, SPECIFY WHETHER THE MODULE WITH PLATE EXCHANGER WILL BE INSTALLED TO THE LEFT OR TO THE RIGHT OF THE CASCADE, THE POSITION REFERS TO THE FRONT VIEW

Reference to images from page 53 on page55

All combinations of modular generators are intended as pre-assembled modules to be assembled together in-line.

Each module inside cabinet is equipped with height adjustable feet.

In the combinations with direct collectors, a module with hydraulic separator or plate exchanger must be installed in order to separate the primary circuit from the secondary circuit.

BASIC COMBINATION WITH DIRECT COLLECTORS				
Models	390	420	450	480
Itaca CH KR 120 heat generator	2	1	-	4
Itaca CH KR 150 heat generator	1	2	3	-
Under-module complete hydraulic unit	3	3	3	4
Insulated flow - return collectors	●	●	●	●
Gas duct	●	●	●	●
Water and gas connecting pipes	●	●	●	●
Flow - return 2-way tap, gas	●	●	●	●
Gas tap	●	●	●	●
Non-return valve	●	●	●	●
High-efficiency - head pump	Self-adj., 12 m	Self-adj., 12 m	Self-adj., 12 m	Self-adj., 12 m
Expansion tank 5l	1	1	1	1
Closing flange unit for water and gas collectors	1	1	1	1
Cascade collector probe	1	1	1	1
Heat transfer paste kit for cascade probe and safety devices on collector	1	1	1	1

Reference to images from page 47 on page49

COMBINATION WITH HYDRAULIC SEPARATOR CONSISTING OF THE BASIC COMBINATION WITH DIRECT COLLECTORS WITH THE ADDITION OF THE FOLLOWING COMPONENTS				
Models	390	420	450	480
Hydraulic separator, with insulation	●	●	●	●
Kit of gaskets + screws and nuts for flange connection	●	●	●	●
Cascade probe holder	●	●	●	●
Automatic bleed on separator	●	●	●	●

WHEN SELECTING THE COMBINATION, SPECIFY WHETHER THE MODULE WITH HYDRAULIC SEPARATOR WILL BE INSTALLED TO THE LEFT OR TO THE RIGHT OF THE CASCADE, THE POSITION REFERS TO THE FRONT VIEW

Reference to images from page 50 on page52

COMBINATION WITH PLATE EXCHANGER CONSISTING OF THE BASIC COMBINATION WITH DIRECT COLLECTORS WITH THE ADDITION OF THE FOLLOWING COMPONENTS				
Models	390	420	450	480
AISI 304 stainless steel plate exchanger - sized according to power level	●	●	●	●
Insulated plate cascade - primary circuit collectors connection kit	●	●	●	●
Insulated system - plate secondary circuit collectors connection kit	●	●	●	●
Kit of gaskets + screws and nuts for flange connection	●	●	●	●
Automatic bleed for collector	●	●	●	●
Cascade probe holder	●	●	●	●

WHEN SELECTING THE COMBINATION, SPECIFY WHETHER THE MODULE WITH PLATE EXCHANGER WILL BE INSTALLED TO THE LEFT OR TO THE RIGHT OF THE CASCADE, THE POSITION REFERS TO THE FRONT VIEW

Reference to images from page 53 on page55

All combinations of modular generators are intended as pre-assembled modules to be assembled together in-line.

Each module inside cabinet is equipped with height adjustable feet.

In the combinations with direct collectors, a module with hydraulic separator or plate exchanger must be installed in order to separate the primary circuit from the secondary circuit.

BASIC COMBINATION WITH DIRECT COLLECTORS				
Models	510	540	570	600
Itaca CH KR 120 heat generator	3	2	1	-
Itaca CH KR 150 heat generator	1	2	3	4
Under-module complete hydraulic unit	4	4	4	4
Insulated flow - return collectors	●	●	●	●
Gas duct	●	●	●	●
Water and gas connecting pipes	●	●	●	●
Flow - return 2-way tap, gas	●	●	●	●
Gas tap	●	●	●	●
Non-return valve	●	●	●	●
High-efficiency - head pump	Self-adj., 12 m	Self-adj., 12 m	Self-adj., 12 m	Self-adj., 12 m
Expansion tank 5l	1	1	1	1
Closing flange unit for water and gas collectors	1	1	1	1
Cascade collector probe	1	1	1	1
Heat transfer paste kit for cascade probe and safety devices on collector	1	1	1	1

Reference to images from page 47 on page49

COMBINATION WITH HYDRAULIC SEPARATOR CONSISTING OF THE BASIC COMBINATION WITH DIRECT COLLECTORS WITH THE ADDITION OF THE FOLLOWING COMPONENTS				
Models	510	540	570	600
Hydraulic separator, with insulation	●	●	●	●
Kit of gaskets + screws and nuts for flange connection	●	●	●	●
Cascade probe holder	●	●	●	●
Automatic bleed on separator	●	●	●	●

WHEN SELECTING THE COMBINATION, SPECIFY WHETHER THE MODULE WITH HYDRAULIC SEPARATOR WILL BE INSTALLED TO THE LEFT OR TO THE RIGHT OF THE CASCADE, THE POSITION REFERS TO THE FRONT VIEW

Reference to images from page 50 on page52

COMBINATION WITH PLATE EXCHANGER CONSISTING OF THE BASIC COMBINATION WITH DIRECT COLLECTORS WITH THE ADDITION OF THE FOLLOWING COMPONENTS				
Models	510	540	570	600
AISI 304 stainless steel plate exchanger - sized according to power level	●	●	●	●
Insulated plate cascade - primary circuit collectors connection kit	●	●	●	●
Insulated system - plate secondary circuit collectors connection kit	●	●	●	●
Kit of gaskets + screws and nuts for flange connection	●	●	●	●
Automatic bleed for collector	●	●	●	●
Cascade probe holder	●	●	●	●

WHEN SELECTING THE COMBINATION, SPECIFY WHETHER THE MODULE WITH PLATE EXCHANGER WILL BE INSTALLED TO THE LEFT OR TO THE RIGHT OF THE CASCADE, THE POSITION REFERS TO THE FRONT VIEW

Reference to images from page 53 on page55

All combinations of modular generators are intended as pre-assembled modules to be assembled together in-line.

Each module inside cabinet is equipped with height adjustable feet.

In the combinations with direct collectors, a module with hydraulic separator or plate exchanger must be installed in order to separate the primary circuit from the secondary circuit.

BASIC COMBINATION WITH DIRECT COLLECTORS				
Models	630	660	690	720
Itaca CH KR 120 heat generator	4	3	2	1
Itaca CH KR 150 heat generator	1	2	3	4
Under-module complete hydraulic unit	5	5	5	5
Insulated flow - return collectors	●	●	●	●
Gas duct	●	●	●	●
Water and gas connecting pipes	●	●	●	●
Flow - return 2-way tap, gas	●	●	●	●
Gas tap	●	●	●	●
Non-return valve	●	●	●	●
High-efficiency - head pump	Self-adj., 12 m	Self-adj., 12 m	Self-adj., 12 m	Self-adj., 12 m
Expansion tank 5l	1	1	1	1
Closing flange unit for water and gas collectors	1	1	1	1
Cascade collector probe	1	1	1	1
Heat transfer paste kit for cascade probe and safety devices on collector	1	1	1	1

Reference to images from page 47 on page49

COMBINATION WITH HYDRAULIC SEPARATOR CONSISTING OF THE BASIC COMBINATION WITH DIRECT COLLECTORS WITH THE ADDITION OF THE FOLLOWING COMPONENTS				
Models	630	660	690	720
Hydraulic separator, with insulation	●	●	●	●
Kit of gaskets + screws and nuts for flange connection	●	●	●	●
Cascade probe holder	●	●	●	●
Automatic bleed on separator	●	●	●	●

WHEN SELECTING THE COMBINATION, SPECIFY WHETHER THE MODULE WITH HYDRAULIC SEPARATOR WILL BE INSTALLED TO THE LEFT OR TO THE RIGHT OF THE CASCADE, THE POSITION REFERS TO THE FRONT VIEW

Reference to images from page 50 on page52

COMBINATION WITH PLATE EXCHANGER CONSISTING OF THE BASIC COMBINATION WITH DIRECT COLLECTORS WITH THE ADDITION OF THE FOLLOWING COMPONENTS				
Models	630	660	690	720
AISI 304 stainless steel plate exchanger - sized according to power level	●	●	●	●
Insulated plate cascade - primary circuit collectors connection kit	●	●	●	●
Insulated system - plate secondary circuit collectors connection kit	●	●	●	●
Kit of gaskets + screws and nuts for flange connection	●	●	●	●
Automatic bleed for collector	●	●	●	●
Cascade probe holder	●	●	●	●

WHEN SELECTING THE COMBINATION, SPECIFY WHETHER THE MODULE WITH PLATE EXCHANGER WILL BE INSTALLED TO THE LEFT OR TO THE RIGHT OF THE CASCADE, THE POSITION REFERS TO THE FRONT VIEW

Reference to images from page 53 on page55

All combinations of modular generators are intended as pre-assembled modules to be assembled together in-line.

Each module inside cabinet is equipped with height adjustable feet.

In the combinations with direct collectors, a module with hydraulic separator or plate exchanger must be installed in order to separate the primary circuit from the secondary circuit.

BASIC COMBINATION WITH DIRECT COLLECTORS					
Models	750	780	810	870	900
Itaca CH KR 120 heat generator	-	4	3	1	-
Itaca CH KR 150 heat generator	5	2	3	5	6
Under-module complete hydraulic unit	5	6	6	6	6
Insulated flow - return collectors	●	●	●	●	●
Gas duct	●	●	●	●	●
Water and gas connecting pipes	●	●	●	●	●
Flow - return 2-way tap, gas	●	●	●	●	●
Gas tap	●	●	●	●	●
Non-return valve	●	●	●	●	●
High-efficiency - head pump	Self-adj., 12 m	Self-adj., 12 m	Self-adj., 12 m	Self-adj., 12 m	Self-adj., 12 m
Expansion tank 5l	1	1	1	1	1
Closing flange unit for water and gas collectors	1	1	1	1	1
Cascade collector probe	1	1	1	1	1
Heat transfer paste kit for cascade probe and safety devices on collector	1	1	1	1	1

Reference to images from page 47 on page49

COMBINATION WITH HYDRAULIC SEPARATOR CONSISTING OF THE BASIC COMBINATION WITH DIRECT COLLECTORS WITH THE ADDITION OF THE FOLLOWING COMPONENTS					
Models	750	780	810	870	900
Hydraulic separator, with insulation	●	●	●	●	●
Kit of gaskets + screws and nuts for flange connection	●	●	●	●	●
Cascade probe holder	●	●	●	●	●
Automatic bleed on separator	●	●	●	●	●

WHEN SELECTING THE COMBINATION, SPECIFY WHETHER THE MODULE WITH HYDRAULIC SEPARATOR WILL BE INSTALLED TO THE LEFT OR TO THE RIGHT OF THE CASCADE, THE POSITION REFERS TO THE FRONT VIEW

Reference to images from page 50 on page52

COMBINATION WITH PLATE EXCHANGER CONSISTING OF THE BASIC COMBINATION WITH DIRECT COLLECTORS WITH THE ADDITION OF THE FOLLOWING COMPONENTS					
Models	750	780	810	870	900
AISI 304 stainless steel plate exchanger - sized according to power level	●	●	●	●	●
Insulated plate cascade - primary circuit collectors connection kit	●	●	●	●	●
Insulated system - plate secondary circuit collectors connection kit	●	●	●	●	●
Kit of gaskets + screws and nuts for flange connection	●	●	●	●	●
Automatic bleed for collector	●	●	●	●	●
Cascade probe holder	●	●	●	●	●

WHEN SELECTING THE COMBINATION, SPECIFY WHETHER THE MODULE WITH PLATE EXCHANGER WILL BE INSTALLED TO THE LEFT OR TO THE RIGHT OF THE CASCADE, THE POSITION REFERS TO THE FRONT VIEW

Reference to images from page 53 on page55

Modular generator for outdoor installation - with direct collectors, combinations with two boilers in models 45 - 60

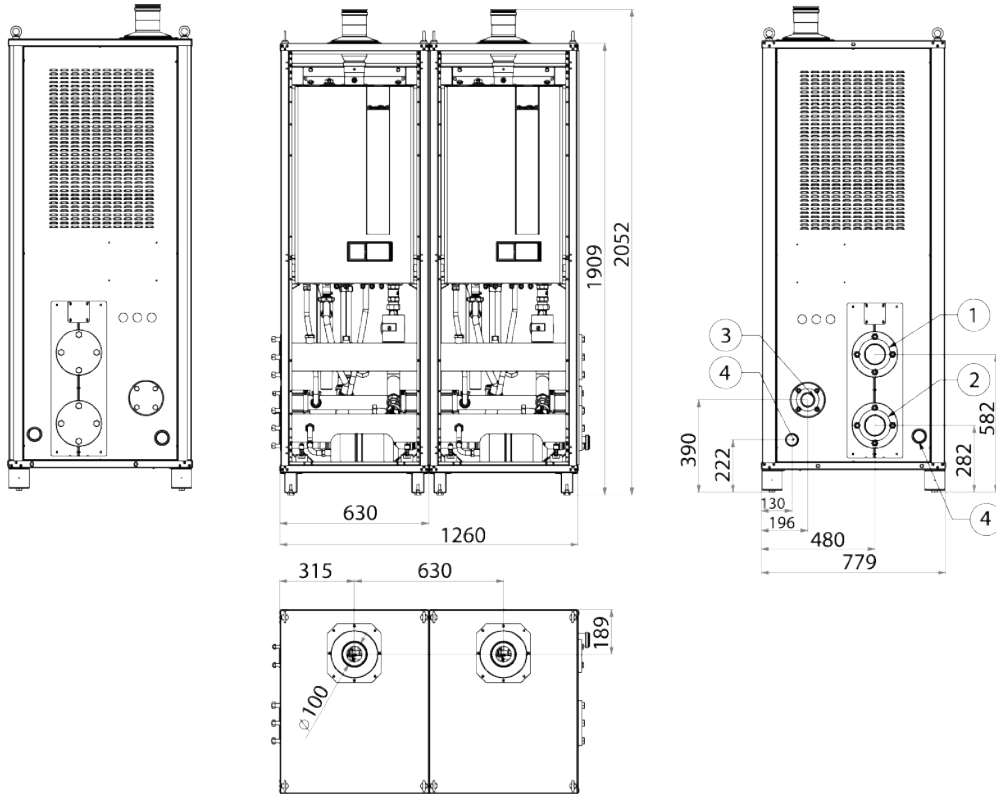

Figure 21: Modular generator with direct collectors

- 1 DN 80 PN 6 flanged connection flow
- 2 PN 6 flanged connection return
- 3 DN 50 flanged connection gas inlet
- 4 DN 50 condensate drain

Model	Modules	Safety valve maximum calibration	Flue gas vent minimum diameter
	Nr (nr x [model])	bar	mm
45	1 (1 x 45)	3	100
60	1 (1 x 60)	3,5	
90 (**)	2 (2 x 45)	3	160
105 (**)	2 (1 x 60 + 1 x 45)		

(**) Versions of modular generators offered to create a low power heating system, spread on 2 heat generators instead of 1

Modular generator for outdoor installation - with direct collectors, combinations with two boilers in models 85 - 120

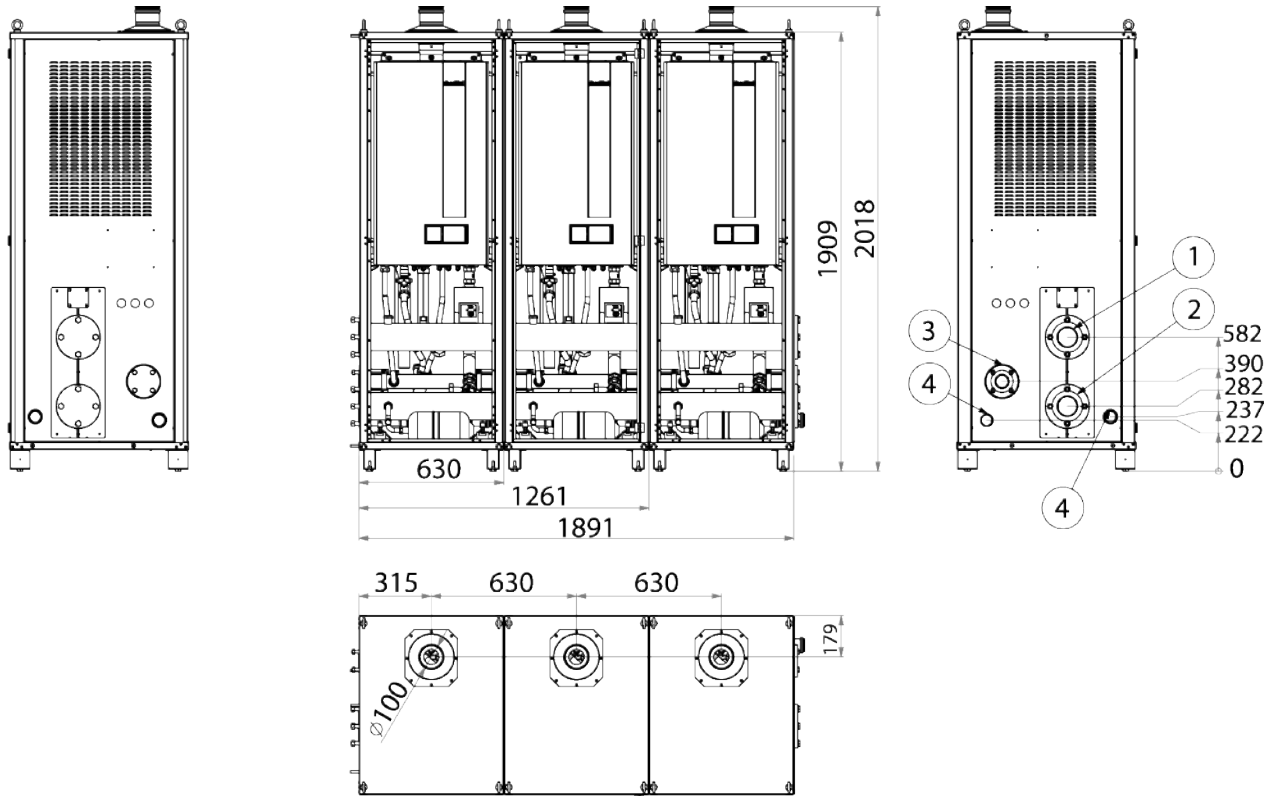

Figure 22: Modular generator with direct collectors

- 1 DN 80 PN 6 flanged connection flow
- 2 PN 6 flanged connection return
- 3 DN 50 flanged connection gas inlet
- 4 DN 50 condensate drain

Model	Modules	Safety valve maximum calibration	Flue gas vent minimum diameter
	Nr (nr x [model])	bar	mm
85	1 (1 x 85)	5	100
120	1 (1 x 120)		
170	2 (2 x 85)		160
205	2 (1 x 85 + 1 x 120)		
240	2 (2 x 120)		
325	3 (1 x 85 + 2 x 120)	200	

Modular generator for outdoor installation - with direct collectors, combinations with two boilers in models 120 - 150

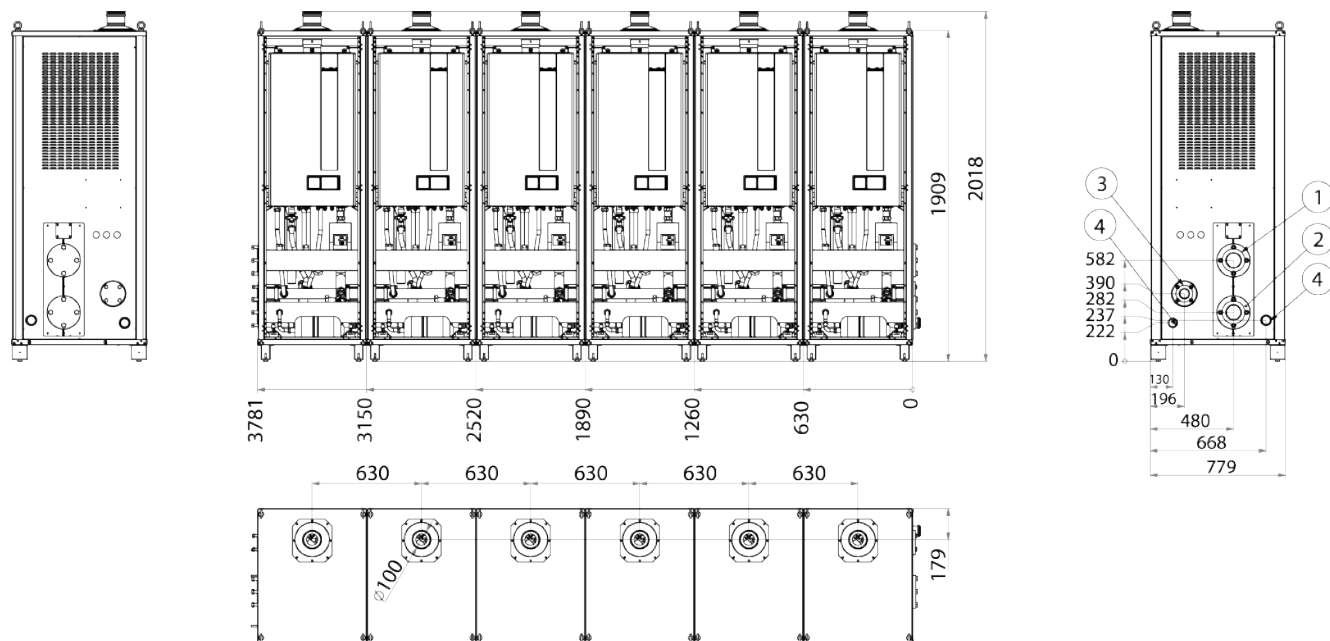

Figure 23: Modular generator with direct collectors

- 1 DN 80 PN 6 flanged connection flow
- 2 PN 6 flanged connection return
- 3 DN 50 flanged connection gas inlet
- 4 DN 50 condensate drain

Model	Modules	Safety valve maximum calibration	Flue gas vent minimum diameter
	Nr (nr x [model])		
150	1 (1 x 150)	5	100
270	2 (1 x 120 + 1 x 150)		160
300	2 (2 x 150)		200
360	3 (3 x 120)		
390	3 (2 x 120 + 1 x 150)		
420	3 (1 x 120 + 2 x 150)		
450	3 (3 x 150)		
480	4 (4 x 120)		
510	4 (3 x 120 + 1 x 150)		
540	4 (2 x 120 + 2 x 150)		
570	4 (1 x 120 + 3 x 150)		
600	4 (4 x 150)		
630	5 (4 x 120 + 1 x 150)		250
660	5 (3 x 120 + 2 x 150)		
690	5 (2 x 120 + 3 x 150)		
720	5 (1 x 120 + 4 x 150)		
750	5 (5 x 150)		
780	6 (4 x 120 + 2 x 150)		
810	6 (3x120 + 3 x 150)		
870	6 (1 x 120 + 5 x 150)		
900	6 (6 x 150)		

MODULAR GENERATOR FOR OUTDOOR INSTALLATION - CONFIGURATION WITH HYDRAULIC SEPARATOR

Modular generator for outdoor installation - with hydraulic separator to the left or to the right, combinations with two boilers in models 45 - 60
SPECIFY WHETHER THE MODULE WITH HYDRAULIC SEPARATOR IS INSTALLED TO THE LEFT OR TO THE RIGHT

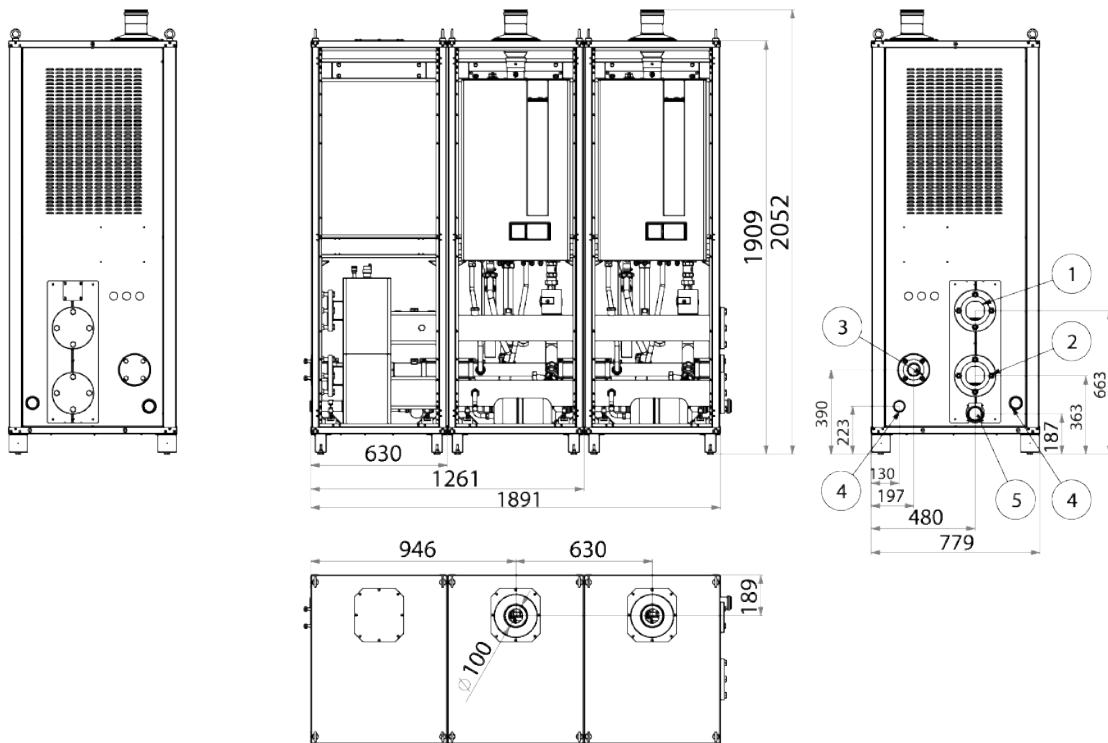

Figure 24: Modular generator with hydraulic separator on the left

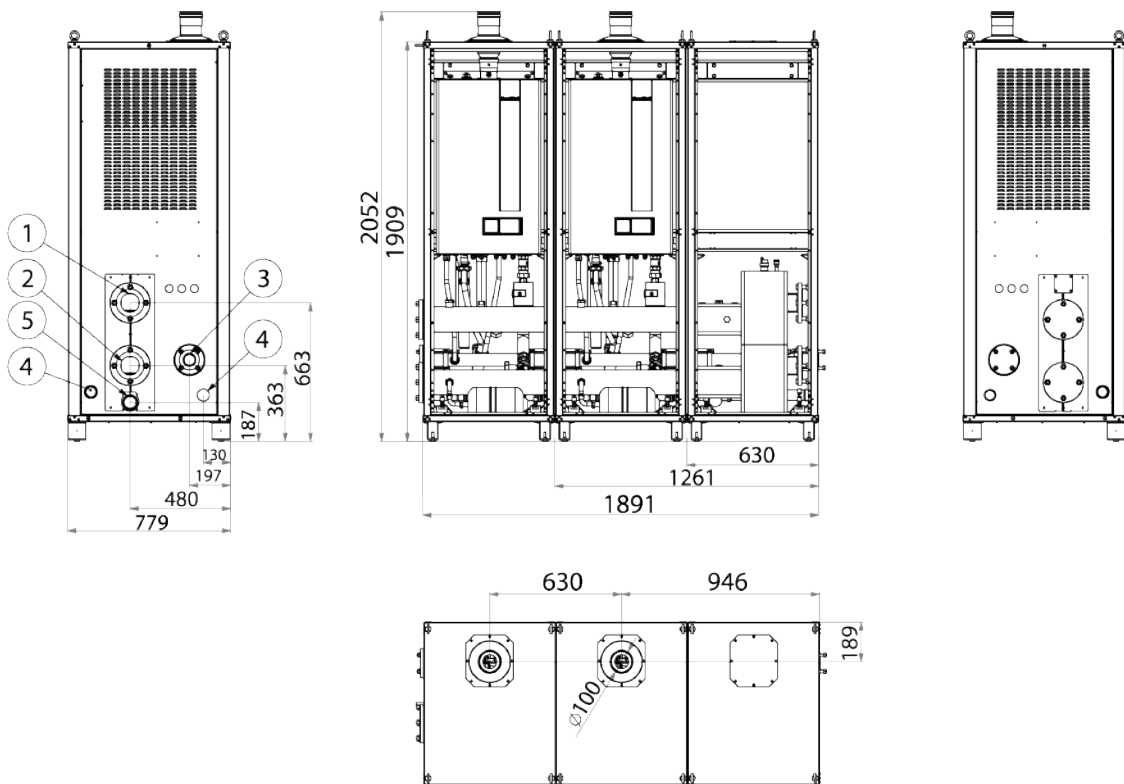

Figure 25: Modular generator with hydraulic separator on the right

- 1 DN 80 PN 6 flanged connection flow
- 2 PN 6 flanged connection return
- 3 DN 50 flanged connection gas inlet
- 4 DN 50 condensate drain
- 5 Drain for separator 1 ½ F

Modular generator for outdoor installation - with hydraulic separator to the left or to the right, combinations with two boilers in models 85 - 120
 SPECIFY WHETHER THE MODULE WITH HYDRAULIC SEPARATOR IS INSTALLED TO THE LEFT OR TO THE RIGHT

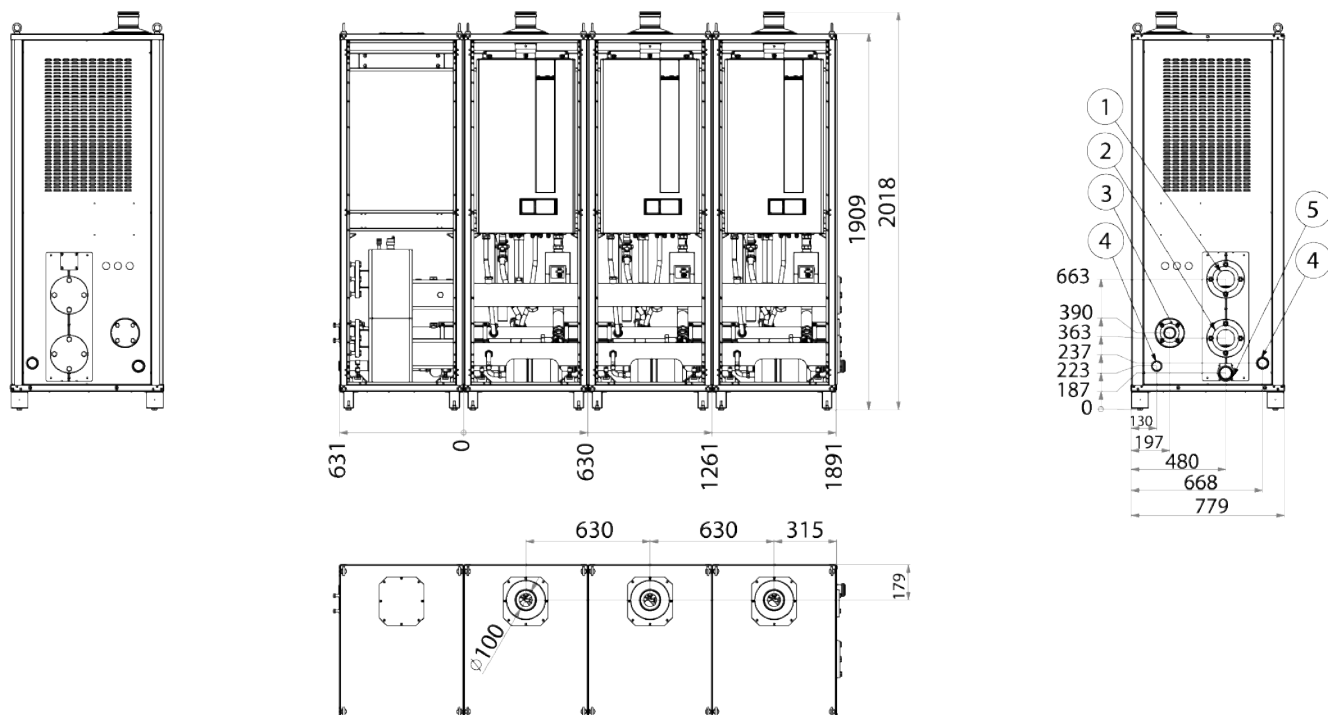

Figure 26: Modular generator with hydraulic separator on the left

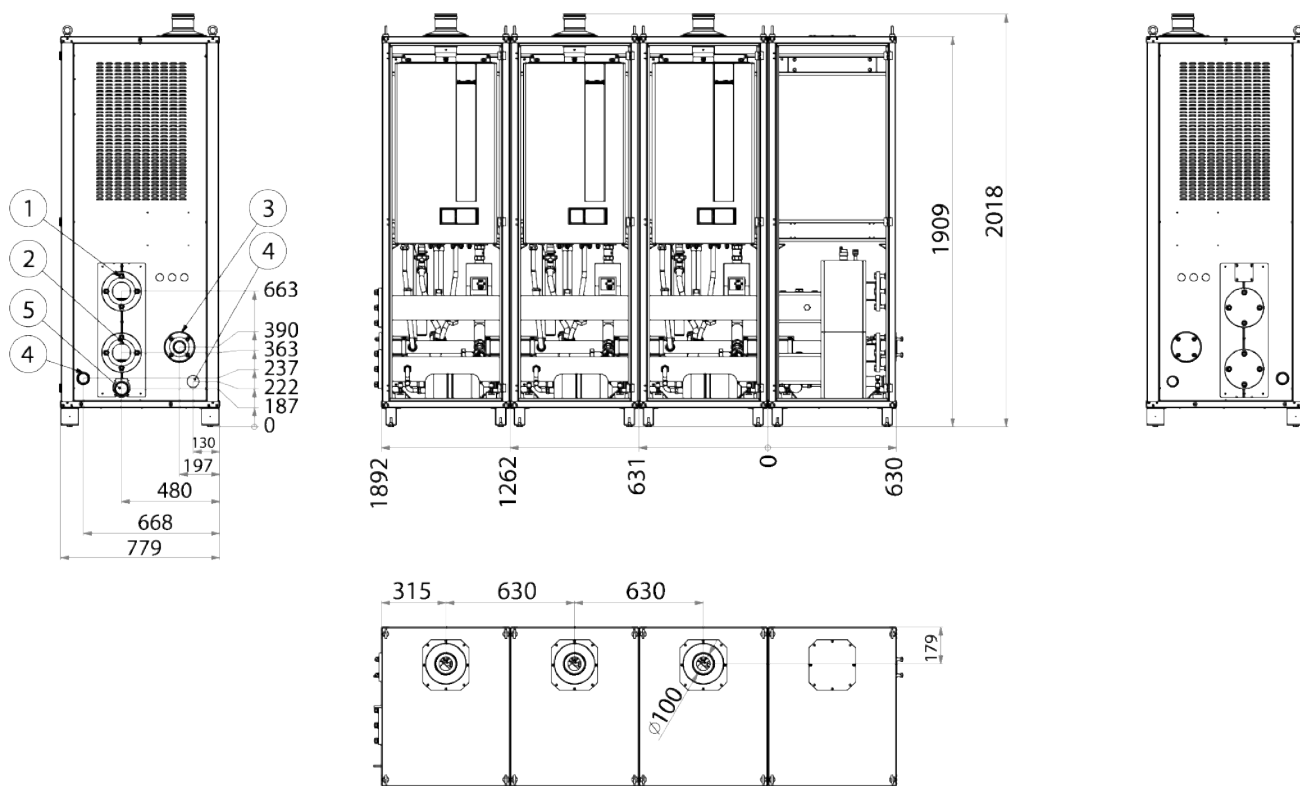

Figure 27: Modular generator with hydraulic separator on the right

- 1 DN 80 PN 6 flanged connection flow
- 2 PN 6 flanged connection return
- 3 DN 50 flanged connection gas inlet
- 4 DN 50 condensate drain
- 5 Drain for separator 1 ½ F

Modular generator for outdoor installation - with hydraulic separator to the left or to the right, combinations with two boilers in models 120 - 150
 SPECIFY WHETHER THE MODULE WITH HYDRAULIC SEPARATOR IS INSTALLED TO THE LEFT OR TO THE RIGHT

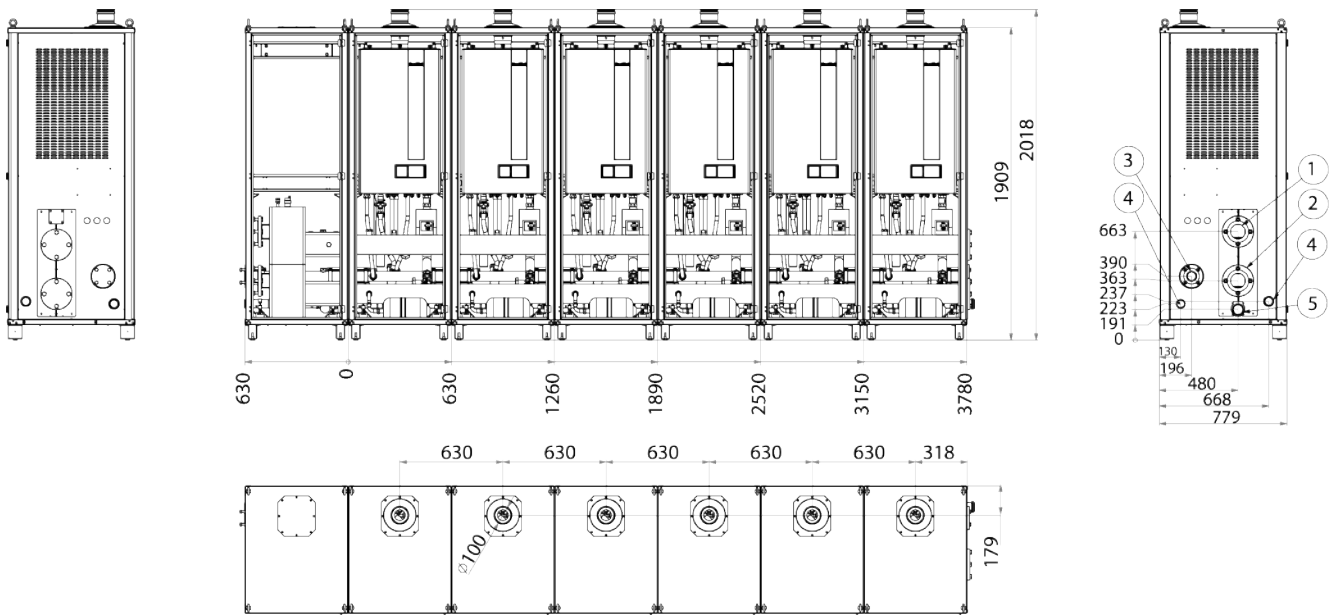

Figure 28: Modular generator with hydraulic separator on the left

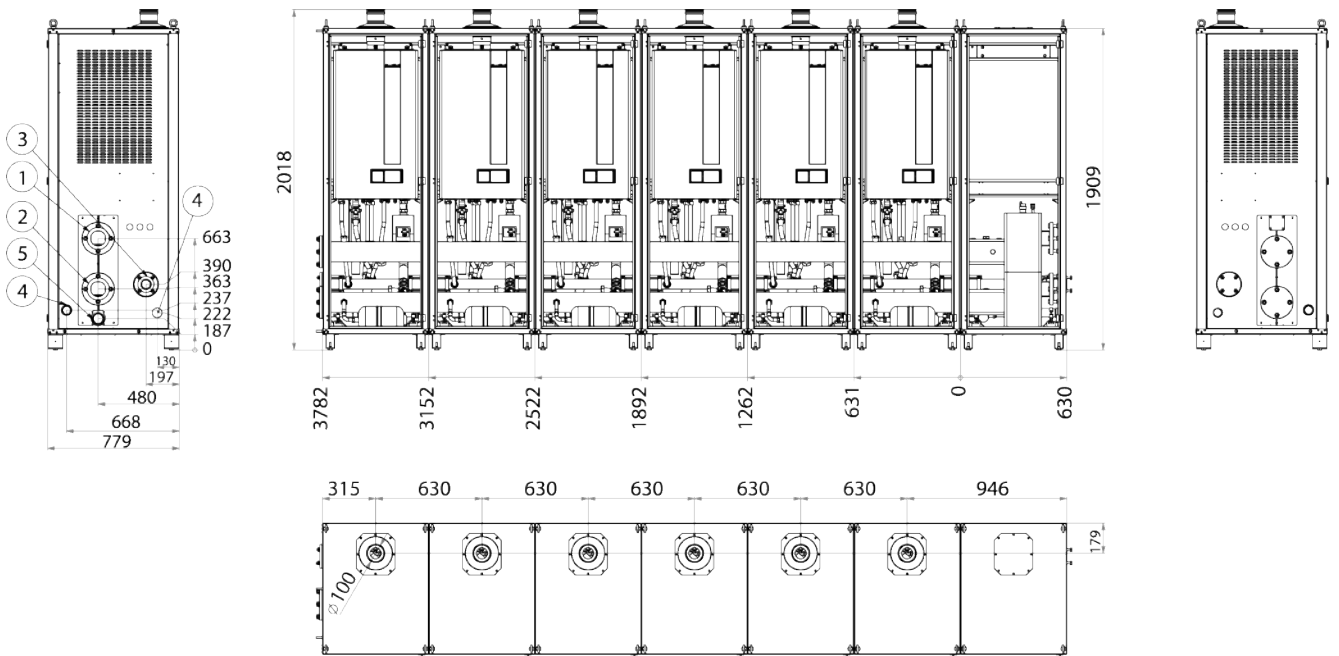

Figure 29: Modular generator with hydraulic separator on the right

- 1 DN 80 PN 6 flanged connection flow
- 2 PN 6 flanged connection return
- 3 DN 50 flanged connection gas inlet
- 4 DN 50 condensate drain
- 5 Drain for separator 1 1/2 F

MODULAR GENERATOR FOR OUTDOOR INSTALLATION - CONFIGURATION WITH PLATE EXCHANGER

Modular generator for outdoor installation - with plate exchanger to the left or to the right, combinations with two boilers in models 45 - 60
SPECIFY WHETHER THE MODULE WITH PLATE EXCHANGER IS INSTALLED TO THE LEFT OR TO THE RIGHT

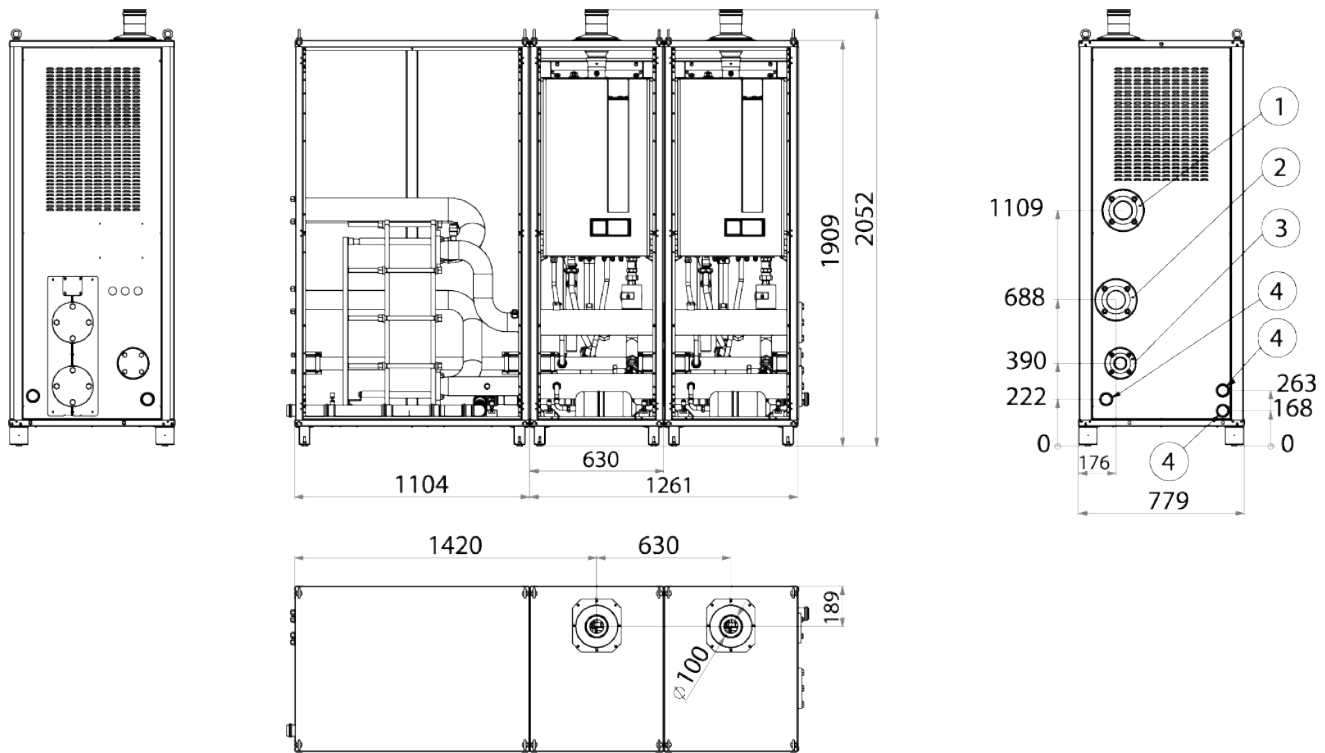

Figure 30: Modular generator with plate exchanger on the left

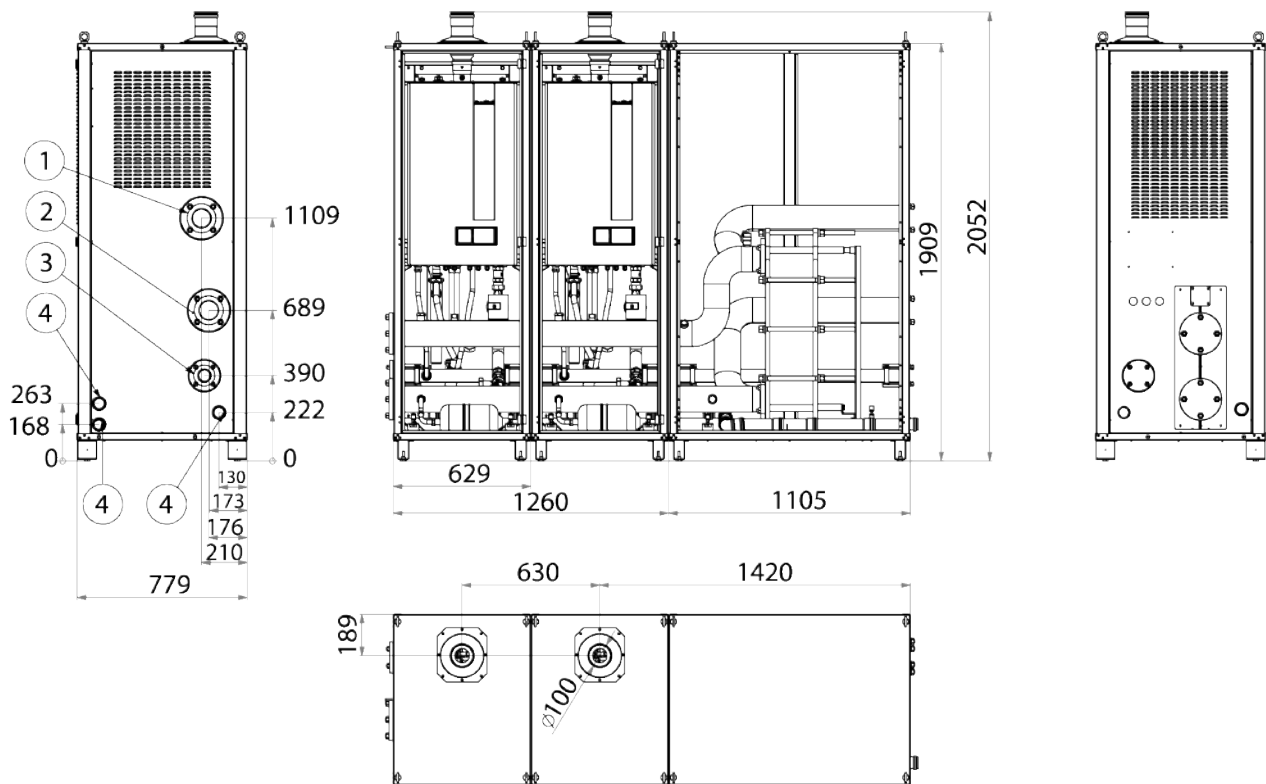

Figure 31: Modular generator with plate exchanger on the right

- 1 DN 80 PN 6 flanged connection flow
- 2 PN 6 flanged connection return
- 3 DN 50 flanged connection gas inlet
- 4 DN 50 condensate drain

Modular generator for outdoor installation - with plate exchanger to the left or to the right, combinations with two boilers in models 85 - 120
 SPECIFY WHETHER THE MODULE WITH PLATE EXCHANGER IS INSTALLED TO THE LEFT OR TO THE RIGHT

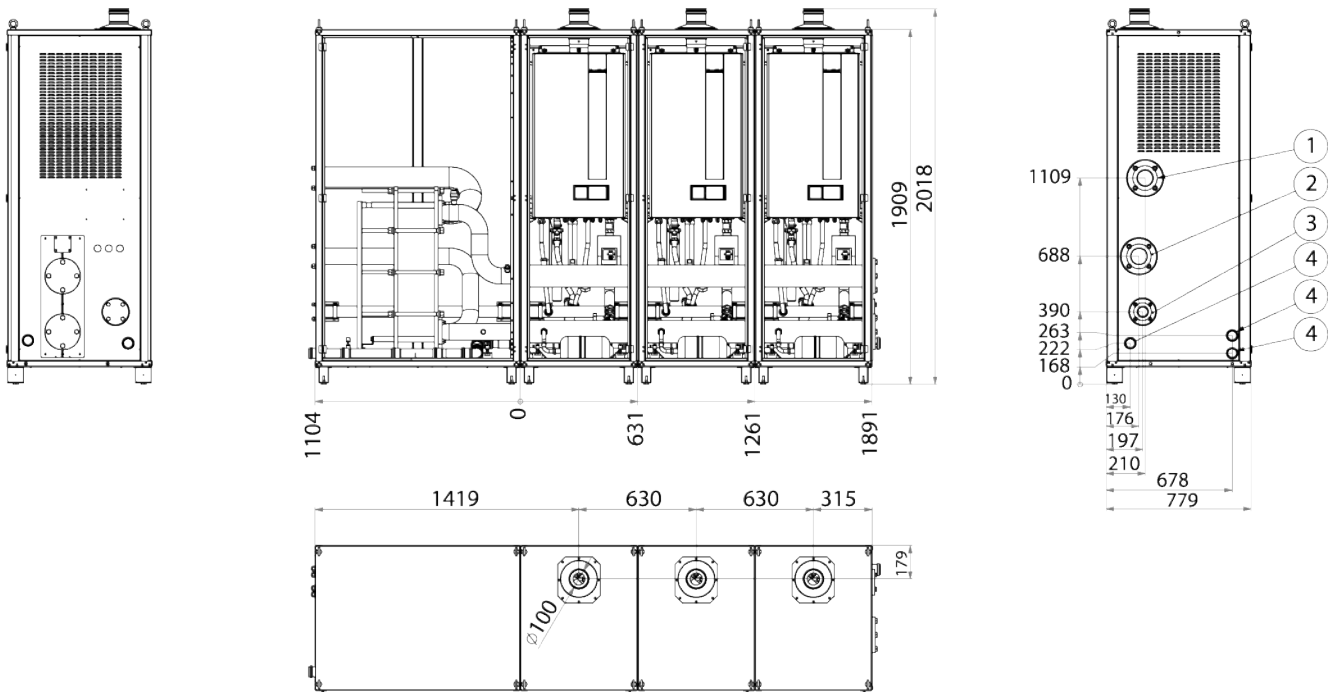

Figure 32: Modular generator with plate exchanger on the left

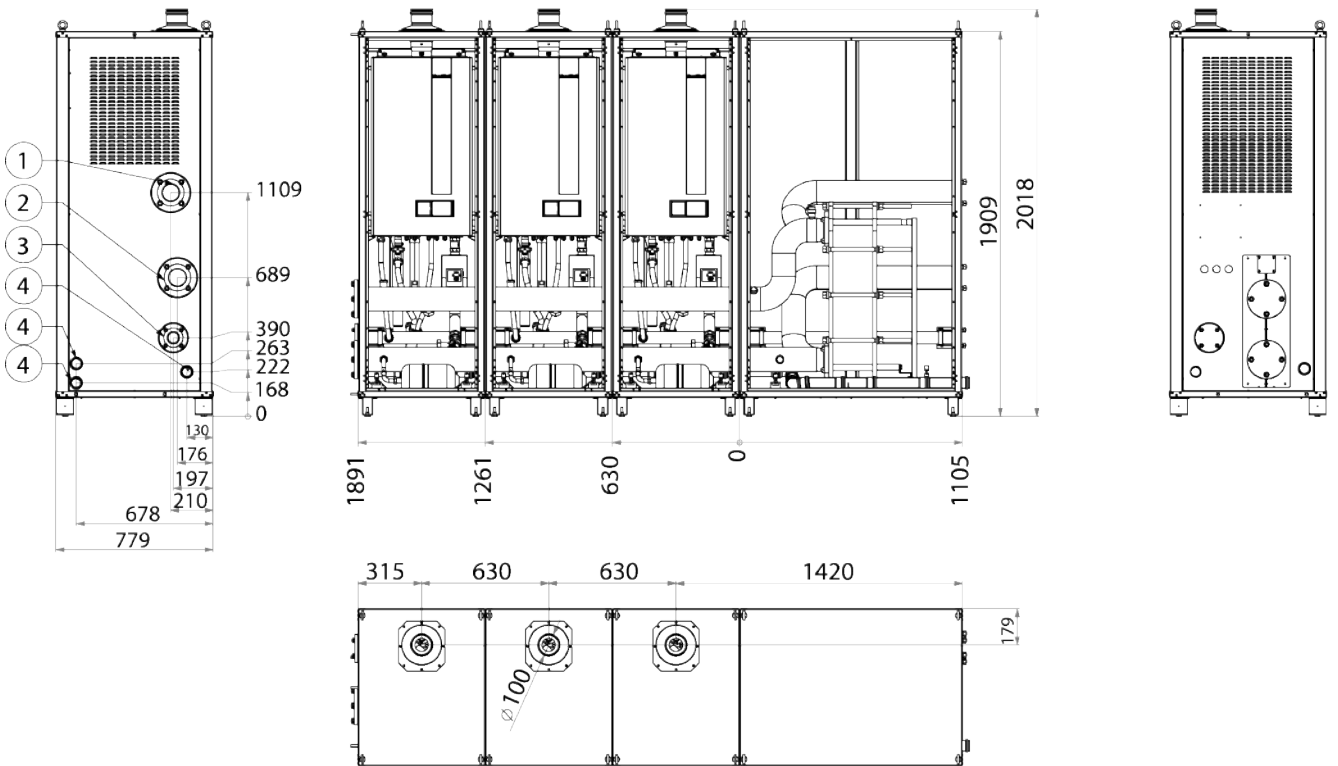

Figure 33: Modular generator with plate exchanger on the right

- 1 DN 80 PN 6 flanged connection flow
- 2 PN 6 flanged connection return
- 3 DN 50 flanged connection gas inlet
- 4 DN 50 condensate drain

Modular generator for outdoor installation - with plate exchanger to the left or to the right, combinations with two boilers in models 120 - 150
 SPECIFY WHETHER THE MODULE WITH PLATE EXCHANGER IS INSTALLED TO THE LEFT OR TO THE RIGHT

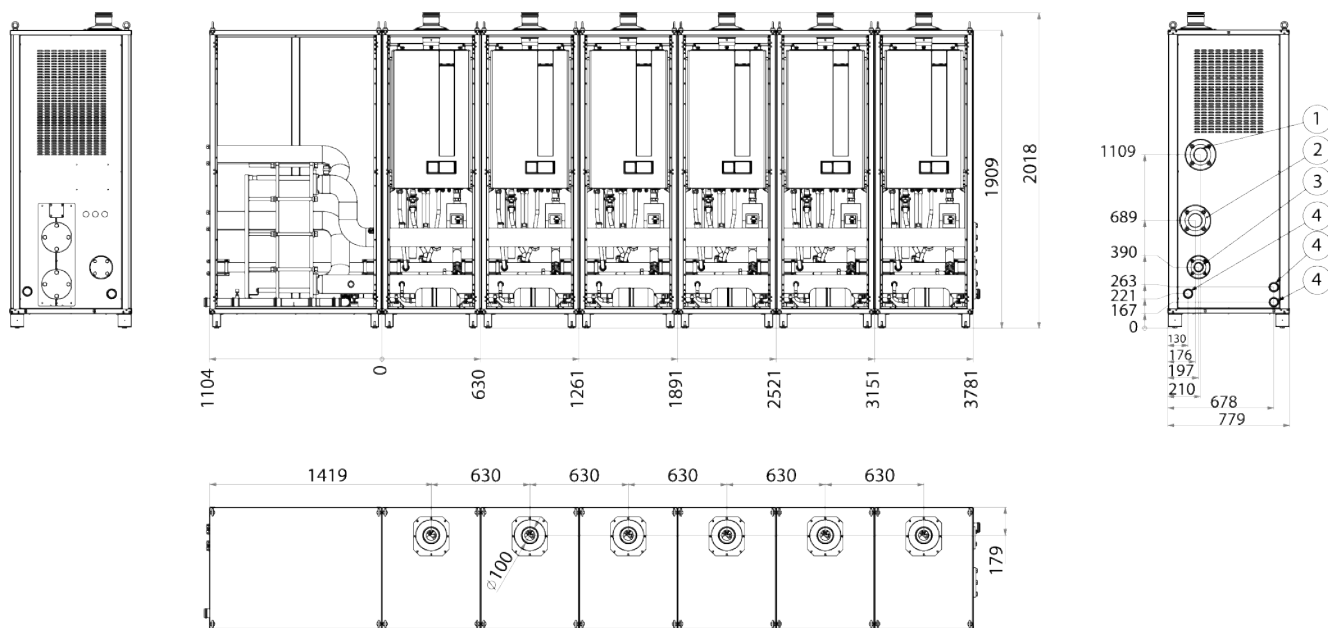

Figure 34: Modular generator with plate exchanger on the left

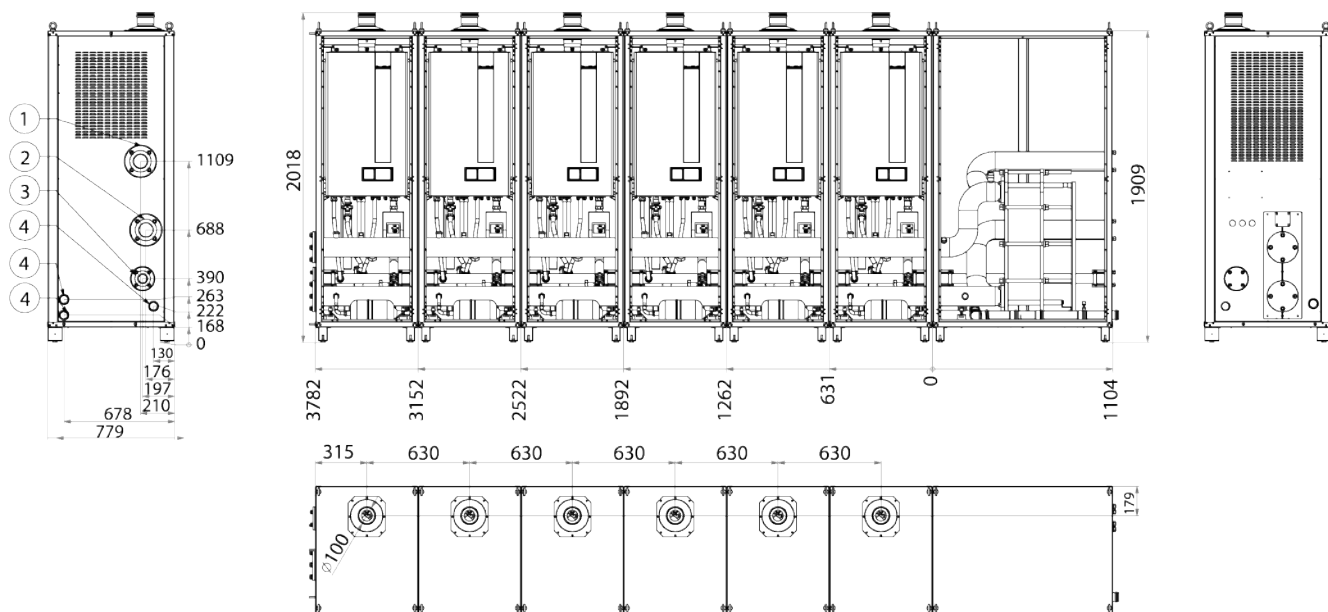

Figure 35: Modular generator with plate exchanger on the right

- 1 DN 80 PN 6 flanged connection flow
- 2 PN 6 flanged connection return
- 3 DN 50 flanged connection gas inlet
- 4 DN 50 condensate drain

CASCADE MODULAR GENERATOR TECHNICAL DATA

Nominal data	um	45	60	90	105
Type	-	C13-C33-C43-C53-C63-C83-C93-C13X-C33X-C43X-C63X-C93X-B23-B23P-C(10)-C(11)			
Nominal heat input (Qn)	kW	40,0	60,0	80,0	100,0
Nominal heat output (80-60°C) (Pn)	kW	38,5	58,3	77,0	96,8
Heat output (50-30°C)	kW	41,5	62,8	83,0	104,3
Reduced heat input (Qr)	kW	4,0	6,0	4,0	
Reduced heat output (80-60°C) (Pr)	kW	3,8	5,8	3,8	
Reduced heat output (50-30°C)	kW	4,3	6,5	4,3	
Useful efficiency at nominal input (80-60°C)	%	97,1			
Useful efficiency at nominal input (50-30°C)	%	105,3	104,6	105,3	105,0
Useful efficiency at 30% (30°C return)	%	108,2	108,4	108,2	108,3
Efficiency at reduced heat input (80-60°C)	%	96,8	97,0	96,8	
Efficiency at reduced heat input (50-30°C)	%	108,2	108,5	108,2	
CH temperature setting range	°C	20-80			
CH maximum working temperature	°C	83			
Exchanger maximum temperature (TMS)	°C	110			
NOx emission class	-	6			
Heating water max. hydraulic pressure (PMS)	bar	3,6	4,2	3,6	
Safety valve calibration pressure	bar	3	3,5	3	
Heating water minimum pressure	bar	0,8			
DHW temperature setting range	°C	65 ÷ 35			
DHW maximum temperature	°C	65			

Nominal data	um	85	120	170
Type	-	C13-C33-C43-C53-C63-C83-C93-C13X-C33X-C43X-C63X-C93X-B23-B23P-C(10)-C(11)		
Nominal heat input (Qn)	kW	81,0	115,0	162,0
Nominal heat output (80-60°C) (Pn)	kW	78,5	112,0	157,0
Heat output (50-30°C)	kW	84,8	122,0	169,6
Reduced heat input (Qr)	kW	9,0	11,5	9,0
Reduced heat output (80-60°C) (Pr)	kW	8,5	11,1	8,5
Reduced heat output (50-30°C)	kW	9,7	12,4	9,7
Useful efficiency at nominal input (80-60°C)	%	96,9	97,4	96,9
Useful efficiency at nominal input (50-30°C)	%	104,8	106,1	104,8
Useful efficiency at 30% (30°C return)	%	108,3	108,6	108,3
Efficiency at reduced heat input (80-60°C)	%	94,8	96,2	94,8
Efficiency at reduced heat input (50-30°C)	%	107,6	108,2	107,6
CH temperature setting range	°C	20-80		
CH maximum working temperature	°C	83		
Exchanger maximum temperature (TMS)	°C	110		
NOx emission class	-	6		
Heating water max. hydraulic pressure (PMS)	bar	6,0		
Safety valve calibration pressure	bar	5		
Heating water minimum pressure	bar	0,8		
DHW temperature setting range	°C	65 ÷ 35		
DHW maximum temperature	°C	65		

Nominal data	um	205	240	325
Type	-	C13-C33-C43-C53-C63-C83-C93-C13X-C33X-C43X-C63X-C93X-B23-B23P-C(10)-C(11)		
Nominal heat input (Qn)	kW	196,0	230,0	311,0
Nominal heat output (80-60°C) (Pn)	kW	190,5	224,0	302,5
Heat output (50-30°C)	kW	206,8	244,0	328,8
Reduced heat input (Qr)	kW	9,0	11,5	9,0
Reduced heat output (80-60°C) (Pr)	kW	8,5	11,1	8,5
Reduced heat output (50-30°C)	kW	9,7	12,4	9,7
Useful efficiency at nominal input (80-60°C)	%	97,2	97,4	97,2
Useful efficiency at nominal input (50-30°C)	%	105,5	106,1	105,7
Useful efficiency at 30% (30°C return)	%	108,5	108,6	108,5
Efficiency at reduced heat input (80-60°C)	%	94,8	96,2	94,8
Efficiency at reduced heat input (50-30°C)	%	107,6	108,2	107,6
CH temperature setting range	°C	20-80		
CH maximum working temperature	°C	83		
Exchanger maximum temperature (TMS)	°C	110		
NOx emission class	-	6		
Heating water max. hydraulic pressure (PMS)	bar	6,0		
Safety valve calibration pressure	bar	5		
Heating water minimum pressure	bar	0,8		
DHW temperature setting range	°C	65 ÷ 35		
DHW maximum temperature	°C	65		

Nominal data	um	150	270	300	360
Type	-	C13-C33-C43-C53-C63-C83-C93-C13X-C33X-C43X-C63X-C93X-B23-B23P-C(10)-C(11)			
Nominal heat input (Qn)	kW	140,0	255,0	280,0	345,0
Nominal heat output (80-60°C) (Pn)	kW	136,3	248,3	272,6	336,0
Heat output (50-30°C)	kW	148,7	270,7	297,4	366,0
Reduced heat input (Qr)	kW	22,5	11,5	22,5	11,5
Reduced heat output (80-60°C) (Pr)	kW	21,6	11,1	21,6	11,1
Reduced heat output (50-30°C)	kW	23,9	12,4	23,9	12,4
Useful efficiency at nominal input (80-60°C)	%	97,3	97,4	97,3	97,4
Useful efficiency at nominal input (50-30°C)	%	106,2			106,1
Useful efficiency at 30% (30°C return)	%	108,4	108,5	108,4	108,6
Efficiency at reduced heat input (80-60°C)	%	96,0	96,2	96,0	96,2
Efficiency at reduced heat input (50-30°C)	%	106,3	108,2	106,3	108,2
CH temperature setting range	°C	20-80			
CH maximum working temperature	°C	83			
Exchanger maximum temperature (TMS)	°C	110			
NOx emission class	-	6			
Heating water max. hydraulic pressure (PMS)	bar	6,0			
Safety valve calibration pressure	bar	5			
Heating water minimum pressure	bar	0,8			
DHW temperature setting range	°C	65 ÷ 35			
DHW maximum temperature	°C	65			

Nominal data	um	390	420	450	480
Type	-	C13-C33-C43-C53-C63-C83-C93-C13X-C33X-C43X-C63X-C93X-B23-B23P-C(10)-C(11)			
Nominal heat input (Qn)	kW	370,0	395,0	420,0	460,0
Nominal heat output (80-60°C) (Pn)	kW	360,3	384,6	408,9	448,0
Heat output (50-30°C)	kW	392,7	419,4	446,1	488,0
Reduced heat input (Qr)	kW	11,5		22,5	11,5
Reduced heat output (80-60°C) (Pr)	kW	11,1		21,6	11,1
Reduced heat output (50-30°C)	kW	12,4		23,9	12,4
Useful efficiency at nominal input (80-60°C)	%	97,4	97,3		97,4
Useful efficiency at nominal input (50-30°C)	%	106,1	106,2		106,1
Useful efficiency at 30% (30°C return)	%	108,5		108,4	108,6
Efficiency at reduced heat input (80-60°C)	%	96,2		96,0	96,2
Efficiency at reduced heat input (50-30°C)	%	108,2		106,3	108,2
CH temperature setting range	°C	20-80			
CH maximum working temperature	°C	83			
Exchanger maximum temperature (TMS)	°C	110			
NOx emission class	-	6			
Heating water max. hydraulic pressure (PMS)	bar	6,0			
Safety valve calibration pressure	bar	5			
Heating water minimum pressure	bar	0,8			
DHW temperature setting range	°C	65 ÷ 35			
DHW maximum temperature	°C	65			

Nominal data	um	510	540	570	600
Type	-	C13-C33-C43-C53-C63-C83-C93-C13X-C33X-C43X-C63X-C93X-B23-B23P-C(10)-C(11)			
Nominal heat input (Qn)	kW	485,0	510,0	535,0	560,0
Nominal heat output (80-60°C) (Pn)	kW	472,3	496,6	520,9	545,2
Heat output (50-30°C)	kW	514,7	541,4	568,1	594,8
Reduced heat input (Qr)	kW	11,5			22,5
Reduced heat output (80-60°C) (Pr)	kW	11,1			21,6
Reduced heat output (50-30°C)	kW	12,4			23,9
Useful efficiency at nominal input (80-60°C)	%	97,4		97,3	
Useful efficiency at nominal input (50-30°C)	%	106,1	106,2		
Useful efficiency at 30% (30°C return)	%	108,6	108,5		108,4
Efficiency at reduced heat input (80-60°C)	%	96,2			96,0
Efficiency at reduced heat input (50-30°C)	%	108,2			106,3
CH temperature setting range	°C	20-80			
CH maximum working temperature	°C	83			
Exchanger maximum temperature (TMS)	°C	110			
NOx emission class	-	6			
Heating water max. hydraulic pressure (PMS)	bar	6,0			
Safety valve calibration pressure	bar	5			
Heating water minimum pressure	bar	0,8			
DHW temperature setting range	°C	65 ÷ 35			
DHW maximum temperature	°C	65			

Nominal data	um	630	660	690	720
Type	-	C13-C33-C43-C53-C63-C83-C93-C13X-C33X-C43X-C63X-C93X-B23-B23P-C(10)-C(11)			
Nominal heat input (Qn)	kW	600,0	625,0	650,0	675,0
Nominal heat output (80-60°C) (Pn)	kW	584,3	608,6	632,9	657,2
Heat output (50-30°C)	kW	636,7	663,4	690,1	716,8
Reduced heat input (Qr)	kW	11,5			
Reduced heat output (80-60°C) (Pr)	kW	11,1			
Reduced heat output (50-30°C)	kW	12,4			
Useful efficiency at nominal input (80-60°C)	%	97,4		97,3	
Useful efficiency at nominal input (50-30°C)	%	106,1		106,2	
Useful efficiency at 30% (30°C return)	%	108,6	108,5		108,4
Efficiency at reduced heat input (80-60°C)	%	96,2			
Efficiency at reduced heat input (50-30°C)	%	108,2			
CH temperature setting range	°C	20-80			
CH maximum working temperature	°C	83			
Exchanger maximum temperature (TMS)	°C	110			
NOx emission class	-	6			
Heating water max. hydraulic pressure (PMS)	bar	6,0			
Safety valve calibration pressure	bar	5			
Heating water minimum pressure	bar	0,8			
DHW temperature setting range	°C	65 ÷ 35			
DHW maximum temperature	°C	65			

Nominal data	um	750	780	810	870	900
Type	-	C13-C33-C43-C53-C63-C83-C93-C13X-C33X-C43X-C63X-C93X-B23-B23P-C(10)-C(11)				
Nominal heat input (Qn)	kW	700,0	740,0	765,0	815,0	840,0
Nominal heat output (80-60°C) (Pn)	kW	681,5	720,6	744,9	793,5	817,8
Heat output (50-30°C)	kW	743,5	785,4	812,1	865,5	892,2
Reduced heat input (Qr)	kW	22,5	11,5			22,5
Reduced heat output (80-60°C) (Pr)	kW	21,6	11,1			21,6
Reduced heat output (50-30°C)	kW	23,9	12,4			23,9
Useful efficiency at nominal input (80-60°C)	%	97,3	97,4		97,3	
Useful efficiency at nominal input (50-30°C)	%	106,2	106,1	106,2		
Useful efficiency at 30% (30°C return)	%	108,4	108,5		108,4	
Efficiency at reduced heat input (80-60°C)	%	96,0	96,2			96,0
Efficiency at reduced heat input (50-30°C)	%	106,3	108,2			106,3
CH temperature setting range	°C	20-80				
CH maximum working temperature	°C	83				
Exchanger maximum temperature (TMS)	°C	110				
NOx emission class	-	6				
Heating water max. hydraulic pressure (PMS)	bar	6,0				
Safety valve calibration pressure	bar	5				
Heating water minimum pressure	bar	0,8				
DHW temperature setting range	°C	65 ÷ 35				
DHW maximum temperature	°C	65				

NOMINAL ELECTRICAL DATA

Nominal electrical data	um	45	60	90	105
Power supply voltage/frequency	V/Hz	230/50			
Module power absorption	W	94	119	188	213
Stand-by module power absorption	W	2		4	
Degree of electrical protection of rack modules	IP	X4D			
Degree of electrical protection of cabinet modules	IP	X5D			

Nominal electrical data	um	85	120	170
Power supply voltage/frequency	V/Hz	230/50		
Module power absorption	W	156	251	312
Stand-by module power absorption	W	3,5		7
Degree of electrical protection of rack modules	IP	X4D		
Degree of electrical protection of cabinet modules	IP	X5D		

Nominal electrical data	um	205	240	325
Power supply voltage/frequency	V/Hz	230/50		
Module power absorption	W	407	502	658
Stand-by module power absorption	W	7		10,5
Degree of electrical protection of rack modules	IP	X4D		
Degree of electrical protection of cabinet modules	IP	X5D		

Nominal electrical data	um	150	270	300	360
Power supply voltage/frequency	V/Hz	230/50			
Module power absorption	W	310	561	620	753
Stand-by module power absorption	W	3,5	7		10,5
Degree of electrical protection of rack modules	IP	X4D			
Degree of electrical protection of cabinet modules	IP	X5D			

Nominal electrical data	um	390	420	450	480
Power supply voltage/frequency	V/Hz	230/50			
Module power absorption	W	812	871	930	1004
Stand-by module power absorption	W	10,5			14
Degree of electrical protection of rack modules	IP	X4D			
Degree of electrical protection of cabinet modules	IP	X5D			

Nominal electrical data	um	510	540	570	600
Power supply voltage/frequency	V/Hz	230/50			
Module power absorption	W	1063	1122	1181	1240
Stand-by module power absorption	W	14			
Degree of electrical protection of rack modules	IP	X4D			
Degree of electrical protection of cabinet modules	IP	X5D			

Nominal electrical data	um	630	660	690	720
Power supply voltage/frequency	V/Hz	230/50			
Module power absorption	W	1314	1373	1432	1491
Stand-by module power absorption	W	17,5			
Degree of electrical protection of rack modules	IP	X4D			
Degree of electrical protection of cabinet modules	IP	X5D			

Nominal electrical data	um	750	780	810	870	900
Power supply voltage/frequency	V/Hz	230/50				
Module power absorption	W	1550	1624	1683	1801	1860
Stand-by module power absorption	W	17,5	21			
Degree of electrical protection of rack modules	IP	X4D				
Degree of electrical protection of cabinet modules	IP	X5D				

DIMENSIONS, WEIGHTS, CONNECTIONS AND VOLUMES

Dimensions - Weights (for indoor installation versions)	um	45	60	90	105
Height of modules in the rack (without flue gas vent)	mm	1761			
Depth of modules in the rack	mm	745			
Width of modules in the rack	mm	630		1286	
Width of modules in the rack with separator	mm	1211		1841	
Width of modules in the rack with exchanger	mm	1750		2380	
Total unladen weight with direct collectors	kg	131	135	233	238
Total unladen weight with hydraulic separator	kg	162	166	264	269
Total unladen weight with plates	kg	240	244	342	347
Total unladen weight with matched plates and collectors	kg	289	293	391	396

Dimensions - Weights (for outdoor installation versions)	um	45	60	90	105
Cabinet height (without flue gas vent)	mm	1909			
Cabinet depth	mm	779			
Cabinet width	mm	630		1260	
Cabinet width with separator	mm	1290		1920	
Cabinet width with exchanger	mm	1764		2394	
Total unladen weight with direct collectors in cabinet	kg	187	191	357	361
Total unladen weight with hydraulic separator in cabinet	kg	303	307	473	477
Total unladen weight with plates	kg	507	511	677	681
Expansion tank of cascade hydraulic kit	l	5		10	

Connections - Water volumes (version for indoor and outdoor installation)	um	45	60	90	105
Flow flange connection	-	DN 80 PN6			
Return flange connection	-	DN 80 PN6			
Gas flange connection	-	DN 50 PN6			
Hydraulic separator drain connection	-	1 ½" F			
Condensate drain connection	-	DN 50			
Module water content	l	11	12	21	22
Water content with hydraulic separator	l	31	32	41	42
Water content with matched plates	l	12	13	22	23
Water content with matched plates and connection collectors	l	23	24	33	34
Exchanger cut	kW	120			

Dimensions - Weights (for indoor installation versions)	um	85	120	170
Height of modules in the rack (without flue gas vent)	mm	1761		
Depth of modules in the rack	mm	745		
Width of modules in the rack	mm	630		1286
Width of modules in the rack with separator	mm	1211		1841
Width of modules in the rack with exchanger	mm	1750		2380
Total unladen weight with direct collectors	kg	160	170	291
Total unladen weight with hydraulic separator	kg	191	201	322
Total unladen weight with plates	kg	269	279	407
Total unladen weight with matched plates and collectors	kg	318	328	456

Dimensions - Weights (for outdoor installation versions)	um	85	120	170
Cabinet height (without flue gas vent)	mm	1909		
Cabinet depth	mm	779		
Cabinet width	mm	630		1260
Cabinet width with separator	mm	1290		1920
Cabinet width with exchanger	mm	1764		2394
Total unladen weight with direct collectors in cabinet	kg	216	226	415
Total unladen weight with hydraulic separator in cabinet	kg	332	342	531
Total unladen weight with plates	kg	536	546	742
Expansion tank of cascade hydraulic kit	l	5		10

Connections - Water volumes (version for indoor and outdoor installation)	um	85	120	170
Flow flange connection	-	DN 80 PN6		
Return flange connection	-	DN 80 PN6		
Gas flange connection	-	DN 50 PN6		
Hydraulic separator drain connection	-	1 ½" F		
Condensate drain connection	-	DN 50		
Module water content	l	13	15	26
Water content with hydraulic separator	l	33	35	46
Water content with matched plates	l	14	16	29
Water content with matched plates and connection collectors	l	25	27	39
Exchanger cut	kW	120		205

Dimensions - Weights (for indoor installation versions)	um	205	240	325
Height of modules in the rack (without flue gas vent)	mm	1761		
Depth of modules in the rack	mm	745		
Width of modules in the rack	mm	1286	1916	
Width of modules in the rack with separator	mm	1841	2471	
Width of modules in the rack with exchanger	mm	2380	3010	
Total unladen weight with direct collectors	kg	301	311	442
Total unladen weight with hydraulic separator	kg	332	342	473
Total unladen weight with plates	kg	417	432	571
Total unladen weight with matched plates and collectors	kg	466	481	620

Dimensions - Weights (for outdoor installation versions)	um	205	240	325
Cabinet height (without flue gas vent)	mm	1909		
Cabinet depth	mm	779		
Cabinet width	mm	1260	1891	
Cabinet width with separator	mm	1920	2550	
Cabinet width with exchanger	mm	2394	3024	
Total unladen weight with direct collectors in cabinet	kg	425	435	633
Total unladen weight with hydraulic separator in cabinet	kg	541	551	749
Total unladen weight with plates	kg	752	767	973
Expansion tank of cascade hydraulic kit	l	10		15

Connections - Water volumes (version for indoor and outdoor installation)	um	205	240	325
Flow flange connection	-	DN 80 PN6		
Return flange connection	-	DN 80 PN6		
Gas flange connection	-	DN 50 PN6		
Hydraulic separator drain connection	-	1 1/2" F		
Condensate drain connection	-	DN 50		
Module water content	l	28	30	43
Water content with hydraulic separator	l	48	50	63
Water content with matched plates	l	31	34	48
Water content with matched plates and connection collectors	l	41	44	58
Exchanger cut	kW	205	300	360

Dimensions - Weights (for indoor installation versions)	um	150	270	300	360
Height of modules in the rack (without flue gas vent)	mm	1761			
Depth of modules in the rack	mm	745			
Width of modules in the rack	mm	630	1286	1916	
Width of modules in the rack with separator	mm	1211	1841	2471	
Width of modules in the rack with exchanger	mm	1750	2380	3010	
Total unladen weight with direct collectors	kg	191	333	354	452
Total unladen weight with hydraulic separator	kg	222	364	385	483
Total unladen weight with plates	kg	307	454	475	581
Total unladen weight with matched plates and collectors	kg	356	503	524	630

Dimensions - Weights (for outdoor installation versions)	um	150	270	300	360
Cabinet height (without flue gas vent)	mm	1909			
Cabinet depth	mm	779			
Cabinet width	mm	630	1260	1891	
Cabinet width with separator	mm	1290	1920	2550	
Cabinet width with exchanger	mm	1764	2394	3024	
Total unladen weight with direct collectors in cabinet	kg	247	456	478	643
Total unladen weight with hydraulic separator in cabinet	kg	363	572	594	759
Total unladen weight with plates	kg	574	788	810	983
Expansion tank of cascade hydraulic kit	l	5	10		15

Connections - Water volumes (version for indoor and outdoor installation)	um	150	270	300	360
Flow flange connection	-	DN 80 PN6			
Return flange connection	-	DN 80 PN6			
Gas flange connection	-	DN 50 PN6			
Hydraulic separator drain connection	-	1 1/2" F			
Condensate drain connection	-	DN 50			
Module water content	l	18	33	35	46
Water content with hydraulic separator	l	38	53	55	66
Water content with matched plates	l	21	37	39	51
Water content with matched plates and connection collectors	l	31	47	49	61
Exchanger cut	kW	205	300		360

Dimensions - Weights (for indoor installation versions)	um	390	420	450	480
Height of modules in the rack (without flue gas vent)	mm	1761			
Depth of modules in the rack	mm	745			
Width of modules in the rack	mm	1916			2520
Width of modules in the rack with separator	mm	2471			3101
Width of modules in the rack with exchanger	mm	3010			3640
Total unladen weight with direct collectors	kg	474	495	517	594
Total unladen weight with hydraulic separator	kg	505	526	548	625
Total unladen weight with plates	kg	607	628	650	739
Total unladen weight with matched plates and collectors	kg	656	677	699	788

Dimensions - Weights (for outdoor installation versions)	um	390	420	450	480
Cabinet height (without flue gas vent)	mm	1909			
Cabinet depth	mm	779			
Cabinet width	mm	1891			2521
Cabinet width with separator	mm	2550			3180
Cabinet width with exchanger	mm	3024			3654
Total unladen weight with direct collectors in cabinet	kg	665	686	708	852
Total unladen weight with hydraulic separator in cabinet	kg	781	802	824	968
Total unladen weight with plates	kg	1009	1030	1052	1208
Expansion tank of cascade hydraulic kit	l	15			20

Connections - Water volumes (version for indoor and outdoor installation)	um	390	420	450	480
Flow flange connection	-	DN 80 PN6			
Return flange connection	-	DN 80 PN6			
Gas flange connection	-	DN 50 PN6			
Hydraulic separator drain connection	-	1 ½" F			
Condensate drain connection	-	DN 50			
Module water content	l	48	51	53	61
Water content with hydraulic separator	l	68	71	73	81
Water content with matched plates	l	54	57	59	69
Water content with matched plates and connection collectors	l	65	68	70	79
Exchanger cut	kW	450			600

Dimensions - Weights (for indoor installation versions)	um	510	540	570	600
Height of modules in the rack (without flue gas vent)	mm	1761			
Depth of modules in the rack	mm	745			
Width of modules in the rack	mm	2520			
Width of modules in the rack with separator	mm	3101			
Width of modules in the rack with exchanger	mm	3640			
Total unladen weight with direct collectors	kg	615	637	658	680
Total unladen weight with hydraulic separator	kg	646	668	689	711
Total unladen weight with plates	kg	760	782	803	825
Total unladen weight with matched plates and collectors	kg	809	831	852	874

Dimensions - Weights (for outdoor installation versions)	um	510	540	570	600
Cabinet height (without flue gas vent)	mm	1909			
Cabinet depth	mm	779			
Cabinet width	mm	2521			
Cabinet width with separator	mm	3180			
Cabinet width with exchanger	mm	3654			
Total unladen weight with direct collectors in cabinet	kg	874	895	917	938
Total unladen weight with hydraulic separator in cabinet	kg	990	1011	1033	1054
Total unladen weight with plates	kg	1230	1251	1273	1294
Expansion tank of cascade hydraulic kit	l	20			

Connections - Water volumes (version for indoor and outdoor installation)	um	510	540	570	600
Flow flange connection	-	DN 80 PN6			
Return flange connection	-	DN 80 PN6			
Gas flange connection	-	DN 50 PN6			
Hydraulic separator drain connection	-	1 ½" F			
Condensate drain connection	-	DN 50			
Module water content	l	63	66	68	71
Water content with hydraulic separator	l	83	86	88	91
Water content with matched plates	l	71	74	76	79
Water content with matched plates and connection collectors	l	81	84	86	89
Exchanger cut	kW	600			

Dimensions - Weights (for indoor installation versions)	um	630	660	690	720
Height of modules in the rack (without flue gas vent)	mm	1761			
Depth of modules in the rack	mm	745			
Width of modules in the rack	mm	3150			
Width of modules in the rack with separator	mm	3731			
Width of modules in the rack with exchanger	mm	4270			
Total unladen weight with direct collectors	kg	757	778	800	821
Total unladen weight with hydraulic separator	kg	788	809	831	852
Total unladen weight with plates	kg	909	930	952	978
Total unladen weight with matched plates and collectors	kg	958	979	1001	1027

Dimensions - Weights (for outdoor installation versions)	um	630	660	690	720
Cabinet height (without flue gas vent)	mm	1909			
Cabinet depth	mm	779			
Cabinet width	mm	3151			
Cabinet width with separator	mm	3810			
Cabinet width with exchanger	mm	4284			
Total unladen weight with direct collectors in cabinet	kg	1083	1104	1126	1147
Total unladen weight with hydraulic separator in cabinet	kg	1199	1220	1242	1263
Total unladen weight with plates	kg	1446	1467	1489	1515
Expansion tank of cascade hydraulic kit	l	25			

Connections - Water volumes (version for indoor and outdoor installation)	um	630	660	690	720
Flow flange connection	-	DN 80 PN6			
Return flange connection	-	DN 80 PN6			
Gas flange connection	-	DN 50 PN6			
Hydraulic separator drain connection	-	1 1/2" F			
Condensate drain connection	-	DN 50			
Module water content	l	79	81	84	86
Water content with hydraulic separator	l	99	101	104	106
Water content with matched plates	l	88	90	93	96
Water content with matched plates and connection collectors	l	98	100	103	106
Exchanger cut	kW	690			780

Dimensions - Weights (for indoor installation versions)	um	750	780	810	870	900
Height of modules in the rack (without flue gas vent)	mm	1761				
Depth of modules in the rack	mm	745				
Width of modules in the rack	mm	3150	3806			
Width of modules in the rack with separator	mm	3731	4361			
Width of modules in the rack with exchanger	mm	4270	4900			
Total unladen weight with direct collectors	kg	843	919	941	984	1005
Total unladen weight with hydraulic separator	kg	874	950	972	1015	1036
Total unladen weight with plates	kg	1000	1076	1103	1146	1167
Total unladen weight with matched plates and collectors	kg	1049	1125	1152	1195	1216

Dimensions - Weights (for outdoor installation versions)	um	750	780	810	870	900
Cabinet height (without flue gas vent)	mm	1909				
Cabinet depth	mm	779				
Cabinet width	mm	3151	3781			
Cabinet width with separator	mm	3810	4440			
Cabinet width with exchanger	mm	4284	4914			
Total unladen weight with direct collectors in cabinet	kg	1169	1313	1334	1377	1399
Total unladen weight with hydraulic separator in cabinet	kg	1285	1429	1450	1493	1515
Total unladen weight with plates	kg	1537	1681	1707	1750	1772
Expansion tank of cascade hydraulic kit	l	25	30			

Connections - Water volumes (version for indoor and outdoor installation)	um	750	780	810	870	900
Flow flange connection	-	DN 80 PN6				
Return flange connection	-	DN 80 PN6				
Gas flange connection	-	DN 50 PN6				
Hydraulic separator drain connection	-	1 1/2" F				
Condensate drain connection	-	DN 50				
Module water content	l	89	96	99	104	106
Water content with hydraulic separator	l	109	116	119	124	126
Water content with matched plates	l	99	106	110	115	117
Water content with matched plates and connection collectors	l	109	116	120	125	127
Exchanger cut	kW	780			900	

FLUE - SHARED COLLECTOR DIMENSIONING DATA

Flue - shared collector dimensioning	um	45	60	90	105
Drain rating	-	B23P			
CO2 at nominal heat input of heating (Natural gas)	%	9,2	9,1	9,2	9,1
Air-flue ΔT at nominal heat input	$^{\circ}C$	57,0			
Flue gas flow at nominal heat input	g/s	19,0	27,3	38,0	46,2
Qn - Residual head available	Pa	30			
Qr - CO2	%	8,9			
Qr - Flue gas temperature - Air temperature	$^{\circ}C$	42	39	42	39
Qr - Flue mass flow	g/sec	1,9	2,8	1,9	
Qr - Residual head available	Pa	5			
Connection diameter to flue gas duct	mm	160			

Flue - shared collector dimensioning	um	85	120	170
Drain rating	-	B23P		
CO2 at nominal heat input of heating (Natural gas)	%	9		
Air-flue ΔT at nominal heat input	$^{\circ}C$	45,3	54	45,3
Flue gas flow at nominal heat input	g/s	37,2	52,7	74,4
Qn - Residual head available	Pa	30		
Qr - CO2	%	9		
Qr - Flue gas temperature - Air temperature	$^{\circ}C$	31,2	35,4	31,2
Qr - Flue mass flow	g/sec	4,1	5,3	4,1
Qr - Residual head available	Pa	5		
Connection diameter to flue gas duct	mm	160		

Flue - shared collector dimensioning	um	205	240	325
Drain rating	-	B23P		
CO2 at nominal heat input of heating (Natural gas)	%	9		
Air-flue ΔT at nominal heat input	$^{\circ}C$	50,4	54	51,7
Flue gas flow at nominal heat input	g/s	89,9	105,4	142,6
Qn - Residual head available	Pa	30		
Qr - CO2	%	9		
Qr - Flue gas temperature - Air temperature	$^{\circ}C$	31,2	35,4	31,2
Qr - Flue mass flow	g/sec	4,1	5,3	4,1
Qr - Residual head available	Pa	5		
Connection diameter to flue gas duct	mm	160		200

Flue - shared collector dimensioning	um	150	270	300	360
Drain rating	-	B23P			
CO2 at nominal heat input of heating (Natural gas)	%	9			
Air-flue ΔT at nominal heat input	$^{\circ}C$	52,6	53,2	52,6	54
Flue gas flow at nominal heat input	g/s	64,2	116,9	128,4	158,1
Qn - Residual head available	Pa	30			
Qr - CO2	%	9			
Qr - Flue gas temperature - Air temperature	$^{\circ}C$	35,4			
Qr - Flue mass flow	g/sec	10,3	5,3	10,3	5,3
Qr - Residual head available	Pa	10	5	10	5
Connection diameter to flue gas duct	mm	160		200	

Flue - shared collector dimensioning	um	390	420	450	480
Drain rating	-	B23P			
CO2 at nominal heat input of heating (Natural gas)	%	9			
Air-flue ΔT at nominal heat input	$^{\circ}C$	53,5	53	52,6	54
Flue gas flow at nominal heat input	g/s	169,6	181,1	192,6	210,8
Qn - Residual head available	Pa	30			
Qr - CO2	%	9			
Qr - Flue gas temperature - Air temperature	$^{\circ}C$	35,4			
Qr - Flue mass flow	g/sec	5,3		10,3	5,3
Qr - Residual head available	Pa	5		10	5
Connection diameter to flue gas duct	mm	200			

Flue - shared collector dimensioning	um	510	540	570	600
Drain rating	-	B23P			
CO2 at nominal heat input of heating (Natural gas)	%	9			
Air-flue ΔT at nominal heat input	$^{\circ}C$	53,6	53,2	52,9	52,6
Flue gas flow at nominal heat input	g/s	222,3	233,8	245,3	256,8
Qn - Residual head available	Pa	30			
Qr - CO2	%	9			
Qr - Flue gas temperature - Air temperature	$^{\circ}C$	35,4			
Qr - Flue mass flow	g/sec	5,3			10,3
Qr - Residual head available	Pa	5			10
Connection diameter to flue gas duct	mm	200			

Flue - shared collector dimensioning	um	630	660	690	720
Drain rating	-	B23P			
CO2 at nominal heat input of heating (Natural gas)	%	9			
Air-flue ΔT at nominal heat input	$^{\circ}C$	53,7	53,4	53,1	52,8
Flue gas flow at nominal heat input	g/s	275,0	286,5	298,0	309,5
Qn - Residual head available	Pa	30			
Qr - CO2	%	9			
Qr - Flue gas temperature - Air temperature	$^{\circ}C$	35,4			
Qr - Flue mass flow	g/sec	5,3			
Qr - Residual head available	Pa	5			
Connection diameter to flue gas duct	mm	250			

Flue - shared collector dimensioning	um	750	780	810	870	900
Drain rating	-	B23P				
CO2 at nominal heat input of heating (Natural gas)	%	9				
Air-flue ΔT at nominal heat input	$^{\circ}C$	52,6	53,5	53,2	52,8	52,6
Flue gas flow at nominal heat input	g/s	321,0	339,2	350,7	373,7	385,2
Qn - Residual head available	Pa	30				
Qr - CO2	%	9				
Qr - Flue gas temperature - Air temperature	$^{\circ}C$	35,4				
Qr - Flue mass flow	g/sec	10,3	5,3			10,3
Qr - Residual head available	Pa	10	5			10
Connection diameter to flue gas duct	mm	250				



DESIGN DATA

Design data	um	45	60	90	105
Qn - Casing heat loss with burner on	%	0,15	0,25	0,15	0,21
Qn - Flue system heat loss with burner on	%	2,80	2,65	2,80	2,71
Qr - Casing heat loss with burner on	%	1,05	1,06	1,05	
Qr - Flue system heat loss with burner on	%	2,19	1,98	2,19	1,98
Qn - Casing heat loss with burner off	%	0,21	0,17	0,21	0,19
Qr - Casing heat loss with burner off	%	1,05	1,06	1,05	
WILO circulation pump power absorption	W	75	130	150	205

Design data	um	85	120	170
Qn - Casing heat loss with burner on	%	0,33	0,00	0,33
Qn - Flue system heat loss with burner on	%	2,80	2,59	2,80
Qr - Casing heat loss with burner on	%	3,31	2,06	3,31
Qr - Flue system heat loss with burner on	%	1,87	1,7	1,87
Qn - Casing heat loss with burner off	%	0,14	0,08	0,14
Qr - Casing heat loss with burner off	%	3,31	2,06	3,31
WILO circulation pump power absorption	W	120	260	240

Design data	um	205	240	325
Qn - Casing heat loss with burner on	%	0,14	0,00	0,09
Qn - Flue system heat loss with burner on	%	2,68	2,59	2,64
Qr - Casing heat loss with burner on	%	2,06		
Qr - Flue system heat loss with burner on	%	1,7		
Qn - Casing heat loss with burner off	%	0,11	0,08	0,10
Qr - Casing heat loss with burner off	%	2,06		
WILO circulation pump power absorption	W	380	520	640

Design data	um	150	270	300	360
Qn - Casing heat loss with burner on	%	0,38	0,21	0,38	0,00
Qn - Flue system heat loss with burner on	%	2,27	2,41	2,27	2,59
Qr - Casing heat loss with burner on	%	2,17	2,06	2,17	2,06
Qr - Flue system heat loss with burner on	%	1,83	1,7	1,83	1,7
Qn - Casing heat loss with burner off	%	0,09			0,08
Qr - Casing heat loss with burner off	%	2,17	2,06	2,17	2,06
WILO circulation pump power absorption	W	260	520		780

Design data	um	390	420	450	480
Qn - Casing heat loss with burner on	%	0,14	0,27	0,38	0,00
Qn - Flue system heat loss with burner on	%	2,47	2,36	2,27	2,59
Qr - Casing heat loss with burner on	%	2,06		2,17	2,06
Qr - Flue system heat loss with burner on	%	1,7		1,83	1,7
Qn - Casing heat loss with burner off	%	0,09			0,08
Qr - Casing heat loss with burner off	%	2,06		2,17	2,06
WILO circulation pump power absorption	W	780			1040

Design data	um	510	540	570	600
Qn - Casing heat loss with burner on	%	0,11	0,21	0,30	0,38
Qn - Flue system heat loss with burner on	%	2,50	2,41	2,34	2,27
Qr - Casing heat loss with burner on	%	2,06			2,17
Qr - Flue system heat loss with burner on	%	1,7			1,83
Qn - Casing heat loss with burner off	%	0,09			
Qr - Casing heat loss with burner off	%	2,06			2,17
WILO circulation pump power absorption	W	1040			

Design data	um	630	660	690	720
Qn - Casing heat loss with burner on	%	0,09	0,17	0,25	0,32
Qn - Flue system heat loss with burner on	%	2,52	2,45	2,38	2,32
Qr - Casing heat loss with burner on	%	2,06			
Qr - Flue system heat loss with burner on	%	1,7			
Qn - Casing heat loss with burner off	%	0,09			
Qr - Casing heat loss with burner off	%	2,06			2,17
WILO circulation pump power absorption	W	1300			

Design data	um	750	780	810	870	900
Qn - Casing heat loss with burner on	%	0,38	0,14	0,21	0,33	0,38
Qn - Flue system heat loss with burner on	%	2,27	2,47	2,41	2,32	2,27
Qr - Casing heat loss with burner on	%	2,17	2,06			2,17
Qr - Flue system heat loss with burner on	%	1,83	1,7			1,83
Qn - Casing heat loss with burner off	%	0,09				
Qr - Casing heat loss with burner off	%	2,17	2,06			2,17
WILO circulation pump power absorption	W	1300	1560			

PLATE EXCHANGER TECHNICAL DATA

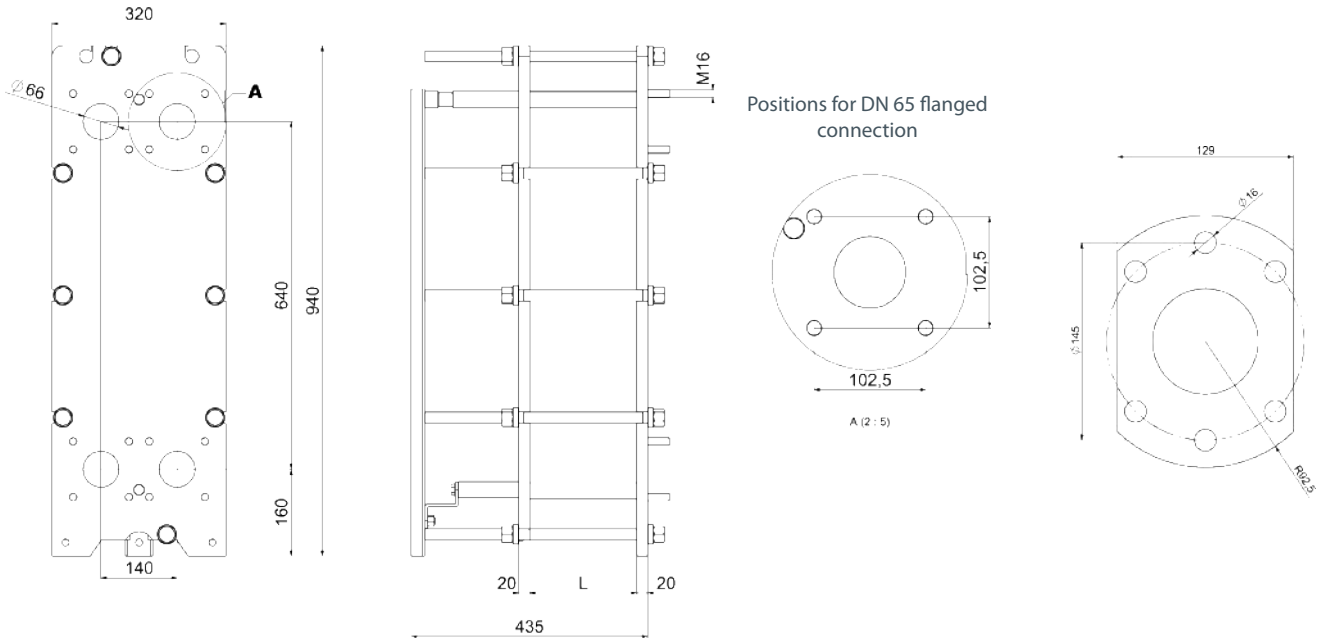

MATERIALS AND CONNECTIONS	
Frame	P355NH
Plates	AISI304
Gaskets	EPDM
Primary connections	P355NH
Secondary connections	P355NH
Tie rods	A193B7
Plate thickness [mm]	0,5
Primary and secondary connections	Flanged DN 65 – M16 tie rods



WARNING

Due to the compact dimensions, to connect the flanges to the exchanger it is necessary to laterally cut the flanges as shown in the drawing at the side, Fondital connection accessories are preset to this purpose.

EXCHANGER PLATES	Code	Plates	Tightening L value	PN	Primary circuit water volume	Secondary circuit water volume	Empty weight	Weight at full load
		no.	mm		bar	l		
UP TO 120	OSCAMPIA27	11	27,5	10	1,4	1,4	110	115
UP TO 205	OSCAMPIA28	21	52,5		2,79	2,79	117	124
UP TO 300	OSCAMPIA29	27	67,5		3,63	3,63	121	130
UP TO 360	OSCAMPIA30	35	87,5		4,47	4,47	128	140
UP TO 450	OSCAMPIA31	41	102,5		5,58	5,58	133	146
UP TO 540	OSCAMPIA32	51	127,5		6,98	6,98	141	157
UP TO 600	OSCAMPIA33	57	142,5		7,81	7,81	145	163
UP TO 690	OSCAMPIA34	63	157,5		8,65	8,65	151	171
UP TO 780	OSCAMPIA35	71	177,5		9,76	9,76	157	179
UP TO 900	OSCAMPIA36	79	197,5		10,88	10,88	163	187

EXCHANGER PLATES	Code	Exchange surface	Inlet primary circuit	Outlet primary circuit	Inlet secondary circuit	Outlet secondary circuit	Primary circuit ΔP	Secondary circuit ΔP
		m ²	°C	°C	°C	°C		
UP TO 120	OSCAMPIA27	1,35	80	60	50	70	20	20
UP TO 205	OSCAMPIA28	2,85						
UP TO 300	OSCAMPIA29	3,75						
UP TO 360	OSCAMPIA30	4,95					21	21
UP TO 450	OSCAMPIA31	5,85						
UP TO 540	OSCAMPIA32	7,35						
UP TO 600	OSCAMPIA33	8,25						
UP TO 690	OSCAMPIA34	9,15					25	25
UP TO 780	OSCAMPIA35	10,35						
UP TO 900	OSCAMPIA36	11,55						

BACK TO BACK CASCADE MODULAR GENERATOR TECHNICAL DATA

Nominal data	um	90	120	145	170	180
Type	-	C13-C33-C43-C53-C63-C83-C93-C13X-C33X-C43X-C63X-C93X-B23-B23P-C(10)-C(11)				
Nominal heat input (Qn)	kW	80	120	141	162	180
Nominal heat output (80-60°C) (Pn)	kW	77,0	116,6	136,8	157	174,9
Heat output (50-30°C)	kW	83	125,6	147,6	169,6	188,4
Reduced heat input (Qr)	kW	4	6		9	6
Reduced heat output (80-60°C) (Pr)	kW	3,8	5,8		8,5	5,8
Reduced heat output (50-30°C)	kW	4,3	6,5		9,7	6,5
Useful efficiency at nominal input (80-60°C)	%	97,1		97	96,9	97,1
Useful efficiency at nominal input (50-30°C)	%	105,3	104,6	104,7	104,8	104,6
Useful efficiency at 30% (30°C return)	%	108,2	108,4	108,3		108,4
Efficiency at reduced heat input (80-60°C)	%	96,8	97		94,8	97
Efficiency at reduced heat input (50-30°C)	%	108,2	108,5		107,6	108,5
CH temperature setting range	°C	20-80				
CH maximum working temperature	°C	83				
Exchanger maximum temperature (TMS)	°C	110				
NOx emission class	-	6				
Heating water max. hydraulic pressure (PMS)	bar	3,6	4,2		6	4,2
Safety valve calibration pressure	bar	3	3,5		5	3,5
Heating water minimum pressure	bar	0,8				
DHW temperature setting range	°C	65 ÷ 35				
DHW maximum temperature	°C	65				

Nominal data	um	205	240	255	270	300
Type	-	C13-C33-C43-C53-C63-C83-C93-C13X-C33X-C43X-C63X-C93X-B23-B23P-C(10)-C(11)				
Nominal heat input (Qn)	kW	201	230	243	255	280
Nominal heat output (80-60°C) (Pn)	kW	195,1	224	235,5	248,3	272,6
Heat output (50-30°C)	kW	210,4	244	254,4	270,7	297,4
Reduced heat input (Qr)	kW	6	11,5	9	11,5	22,5
Reduced heat output (80-60°C) (Pr)	kW	5,8	11,1	8,5	11,1	21,6
Reduced heat output (50-30°C)	kW	6,5	12,4	9,7	12,4	23,9
Useful efficiency at nominal input (80-60°C)	%	97	97,4	96,9	97,3	
Useful efficiency at nominal input (50-30°C)	%	104,7	106,1	104,8	106,2	
Useful efficiency at 30% (30°C return)	%	108,4	108,6	108,3	108,5	108,4
Efficiency at reduced heat input (80-60°C)	%	97	96,2	94,8	96,2	96
Efficiency at reduced heat input (50-30°C)	%	108,5	108,2	107,6	108,2	106,3
CH temperature setting range	°C	20-80				
CH maximum working temperature	°C	83				
Exchanger maximum temperature (TMS)	°C	110				
NOx emission class	-	6				
Heating water max. hydraulic pressure (PMS)	bar	4,2	6			
Safety valve calibration pressure	bar	3,5	5			
Heating water minimum pressure	bar	0,8				
DHW temperature setting range	°C	65 ÷ 35				
DHW maximum temperature	°C	65				

Nominal data	um	360	390	450	480	540
Type	-	C13-C33-C43-C53-C63-C83-C93-C13X-C33X-C43X-C63X-C93X-B23-B23P-C(10)-C(11)				
Nominal heat input (Qn)	kW	345	370	420	460	510
Nominal heat output (80-60°C) (Pn)	kW	336	360,3	408,9	448	496,6
Heat output (50-30°C)	kW	366	392,7	446,1	488	541,4
Reduced heat input (Qr)	kW	11,5		22,5	11,5	
Reduced heat output (80-60°C) (Pr)	kW	11,1		21,6	11,1	
Reduced heat output (50-30°C)	kW	12,4		23,9	12,4	
Useful efficiency at nominal input (80-60°C)	%	97,4		97,3	97,4	97,3
Useful efficiency at nominal input (50-30°C)	%	106,1		106,2	106,1	106,2
Useful efficiency at 30% (30°C return)	%	108,6	108,5	108,4	108,6	108,5
Efficiency at reduced heat input (80-60°C)	%	96,2		96	96,2	
Efficiency at reduced heat input (50-30°C)	%	108,2		106,3	108,2	
CH temperature setting range	°C	20-80				
CH maximum working temperature	°C	83				
Exchanger maximum temperature (TMS)	°C	110				
NOx emission class	-	6				
Heating water max. hydraulic pressure (PMS)	bar	6				
Safety valve calibration pressure	bar	5				
Heating water minimum pressure	bar	0,8				
DHW temperature setting range	°C	65 ÷ 35				
DHW maximum temperature	°C	65				

Nominal data	um	600	660	750	810	900
Type	-	C13-C33-C43-C53-C63-C83-C93-C13X-C33X-C43X-C63X-C93X-B23-B23P-C(10)-C(11)				
Nominal heat input (Qn)	kW	560	625	700	765	840
Nominal heat output (80-60°C) (Pn)	kW	545,2	608,6	681,5	744,9	817,8
Heat output (50-30°C)	kW	594,8	663,4	743,5	812,1	892,2
Reduced heat input (Qr)	kW	22,5	11,5	22,5	11,5	22,5
Reduced heat output (80-60°C) (Pr)	kW	21,6	11,1	21,6	11,1	21,6
Reduced heat output (50-30°C)	kW	23,9	12,4	23,9	12,4	23,9
Useful efficiency at nominal input (80-60°C)	%	97,3	97,4	97,3		
Useful efficiency at nominal input (50-30°C)	%	106,2	106,1	106,2		
Useful efficiency at 30% (30°C return)	%	108,4	108,5	108,4	108,5	108,4
Efficiency at reduced heat input (80-60°C)	%	96	96,2	96	96,2	96
Efficiency at reduced heat input (50-30°C)	%	106,3	108,2	106,3	108,2	106,3
CH temperature setting range	°C	20-80				
CH maximum working temperature	°C	83				
Exchanger maximum temperature (TMS)	°C	110				
NOx emission class	-	6				
Heating water max. hydraulic pressure (PMS)	bar	6				
Safety valve calibration pressure	bar	5				
Heating water minimum pressure	bar	0,8				
DHW temperature setting range	°C	65 ÷ 35				
DHW maximum temperature	°C	65				

NOMINAL ELECTRICAL DATA

Nominal electrical data	um	90	120	145	170	180
Power supply voltage/frequency	V/Hz	230/50				
Module power absorption	W	188	238	275	312	357
Stand-by module power absorption	W	4		5,5	7	6
Degree of electrical protection of rack modules	IP	X4D				
Nominal electrical data	um	205	240	255	270	300
Power supply voltage/frequency	V/Hz	230/50				
Module power absorption	W	394	502	468	561	620
Stand-by module power absorption	W	7,5	7	11	7	
Degree of electrical protection of rack modules	IP	X4D				
Nominal electrical data	um	360	390	450	480	540
Power supply voltage/frequency	V/Hz	230/50				
Module power absorption	W	753	812	930	1004	1122
Stand-by module power absorption	W	10,5			14	
Degree of electrical protection of rack modules	IP	X4D				
Nominal electrical data	um	600	660	750	810	900
Power supply voltage/frequency	V/Hz	230/50				
Module power absorption	W	1240	1373	1550	1683	1860
Stand-by module power absorption	W	14	17,5		21	
Degree of electrical protection of rack modules	IP	X4D				

DIMENSIONS, WEIGHTS, CONNECTIONS AND VOLUMES

Dimensions - Weights (for indoor installation versions)	um	90	120	145	170	180
Height of modules in the rack (without flue gas vent)	mm	1729				
Depth of modules in the rack	mm	1054				
Width of modules in the rack	mm	658				1288
Width of modules in the rack with separator	mm	1211				1841
Width of modules in the rack with exchanger	mm	1748				2378
Total unladen weight with direct collectors	kg	172	186	211	236	293
Total unladen weight with hydraulic separator	kg	203	217	242	267	324
Total unladen weight with plates	kg	302	316	348	373	430
Total unladen weight with matched plates and collectors	kg	330	344	376	401	458

Connections - Water volumes	um	90	120	145	170	180
Flow flange connection	-	DN 80 PN6				
Return flange connection	-	DN 80 PN6				
Gas flange connection	-	DN 50 PN6				
Hydraulic separator drain connection	-	1 ½" F				
Condensate drain connection	-	DN 50				
Module water content	l	14	17	18	19	28
Water content with hydraulic separator	l	34	37	38	39	48
Water content with matched plates	l	15	18	21	22	31
Water content with matched plates and connection collectors	l	26	29	31	32	41
Exchanger cut	kW	120			205	

Dimensions - Weights (for indoor installation versions)	um	205	240	255	270	300
Height of modules in the rack (without flue gas vent)	mm	1729				
Depth of modules in the rack	mm	1054	1422	1054	1422	
Width of modules in the rack	mm	1288	658	1288	658	
Width of modules in the rack with separator	mm	1841	1211	1841	1211	
Width of modules in the rack with exchanger	mm	2378	1748	2378	1748	
Total unladen weight with direct collectors	kg	317	257	367	278	300
Total unladen weight with hydraulic separator	kg	348	288	398	309	331
Total unladen weight with plates	kg	454	399	509	420	442
Total unladen weight with matched plates and collectors	kg	482	427	537	448	470

Connections - Water volumes	um	205	240	255	270	300
Flow flange connection	-	DN 80 PN6				
Return flange connection	-	DN 80 PN6				
Gas flange connection	-	DN 50 PN6				
Hydraulic separator drain connection	-	1 ½" F				
Condensate drain connection	-	DN 50				
Module water content	l	29	24	31	26	29
Water content with hydraulic separator	l	49	44	51	46	49
Water content with matched plates	l	32	28	35	30	33
Water content with matched plates and connection collectors	l	42	38	45	40	43
Exchanger cut	kW	205	300			

Dimensions - Weights (for indoor installation versions)	um	360	390	450	480	540
Height of modules in the rack (without flue gas vent)	mm	1729				
Depth of modules in the rack	mm	1422				
Width of modules in the rack	mm	1288				
Width of modules in the rack with separator	mm	1841				
Width of modules in the rack with exchanger	mm	2378				
Total unladen weight with direct collectors	kg	399	420	463	494	537
Total unladen weight with hydraulic separator	kg	430	451	494	525	568
Total unladen weight with plates	kg	548	574	617	656	699
Total unladen weight with matched plates and collectors	kg	576	602	645	684	727

Connections - Water volumes	um	360	390	450	480	540
Flow flange connection	-	DN 80 PN6				
Return flange connection	-	DN 80 PN6				
Gas flange connection	-	DN 50 PN6				
Hydraulic separator drain connection	-	1 ½" F				
Condensate drain connection	-	DN 50				
Module water content	l	39	41	46	47	52
Water content with hydraulic separator	l	59	61	66	67	72
Water content with matched plates	l	44	47	52	55	60
Water content with matched plates and connection collectors	l	54	58	63	65	70
Exchanger cut	kW	360	450		600	

Dimensions - Weights (for indoor installation versions)	um	600	660	750	810	900
Height of modules in the rack (without flue gas vent)	mm	1729				
Depth of modules in the rack	mm	1422				
Width of modules in the rack	mm	1288	1918			
Width of modules in the rack with separator	mm	1841	2471			
Width of modules in the rack with exchanger	mm	2378	3008			
Total unladen weight with direct collectors	kg	580	679	743	796	861
Total unladen weight with hydraulic separator	kg	611	710	774	827	892
Total unladen weight with plates	kg	746	852	922	979	1044
Total unladen weight with matched plates and collectors	kg	774	880	950	1007	1072

Connections - Water volumes	um	600	660	750	810	900
Flow flange connection	-	DN 80 PN6				
Return flange connection	-	DN 80 PN6				
Gas flange connection	-	DN 50 PN6				
Hydraulic separator drain connection	-	1 1/2" F				
Condensate drain connection	-	DN 50				
Module water content	l	57	67	75	78	86
Water content with hydraulic separator	l	77	87	95	98	106
Water content with matched plates	l	65	76	85	89	97
Water content with matched plates and connection collectors	l	75	86	95	99	107
Exchanger cut	kW	600	690	780	900	

FLUE - SHARED COLLECTOR DIMENSIONING DATA

Flue - shared collector dimensioning	um	90	120	145	170	180
Drain rating	-	B23P				
CO2 at nominal heat input of heating (Natural gas)	%	9,2	9,1	9		9,1
Air-flue ΔT at nominal heat input	$^{\circ}C$	57		50,3	45,3	57
Flue gas flow at nominal heat input	g/s	38	54,5	64,5	74,4	81,8
Qn - Residual head available	Pa	30				
Qr - CO2	%	8,9			9	8,9
Qr - Flue gas temperature - Air temperature	$^{\circ}C$	42	39		31,2	39
Qr - Flue mass flow	g/sec	1,9	2,8		4,1	2,8
Qr - Residual head available	Pa	5				
Connection diameter to flue gas duct	mm	200				

Flue - shared collector dimensioning	um	205	240	255	270	300
Drain rating	-	B23P				
CO2 at nominal heat input of heating (Natural gas)	%	9,1	9			
Air-flue ΔT at nominal heat input	$^{\circ}C$	52,3	54	45,3	53,2	52,6
Flue gas flow at nominal heat input	g/s	91,7	105,4	111,6	116,9	128,4
Qn - Residual head available	Pa	30				
Qr - CO2	%	8,9	9			
Qr - Flue gas temperature - Air temperature	$^{\circ}C$	39	35,4	31,2	35,4	
Qr - Flue mass flow	g/sec	2,8	5,3	4,1	5,3	10,3
Qr - Residual head available	Pa	5				10
Connection diameter to flue gas duct	mm	200				

Flue - shared collector dimensioning	um	360	390	450	480	540
Drain rating	-	B23P				
CO2 at nominal heat input of heating (Natural gas)	%	9				
Air-flue ΔT at nominal heat input	$^{\circ}C$	54	53,5	52,6	54	53,2
Flue gas flow at nominal heat input	g/s	158,1	169,6	192,6	210,8	233,8
Qn - Residual head available	Pa	30				
Qr - CO2	%	9				
Qr - Flue gas temperature - Air temperature	$^{\circ}C$	35,4				
Qr - Flue mass flow	g/sec	5,3		10,3	5,3	
Qr - Residual head available	Pa	5		10	5	
Connection diameter to flue gas duct	mm	200				

Flue - shared collector dimensioning	um	600	660	750	810	900
Drain rating	-	B23P				
CO2 at nominal heat input of heating (Natural gas)	%	9				
Air-flue ΔT at nominal heat input	°C	52,6	53,4	52,6	53,2	52,6
Flue gas flow at nominal heat input	g/s	256,8	286,5	321	350,7	385,2
Qn - Residual head available	Pa	30				
Qr - CO2	%	9				
Qr - Flue gas temperature - Air temperature	°C	35,4				
Qr - Flue mass flow	g/sec	10,3	5,3	10,3	5,3	10,3
Qr - Residual head available	Pa	10	5	10	5	10
Connection diameter to flue gas duct	mm	200	250			

DESIGN DATA













Design data	um	90	120	145	170	180
Qn - Casing heat loss with burner on	%	0,15	0,25	0,3	0,33	0,25
Qn - Flue system heat loss with burner on	%	2,8	2,65	2,74	2,8	2,65
Qr - Casing heat loss with burner on	%	1,05	1,06		3,31	1,06
Qr - Flue system heat loss with burner on	%	2,19	1,98		1,87	1,98
Qn - Casing heat loss with burner off	%	0,21	0,17	0,15	0,14	0,17
Qr - Casing heat loss with burner off	%	0,21	0,17		0,14	0,17
WILO circulation pump power absorption	W	150	260	270	280	390

Design data	um	205	240	255	270	300
Qn - Casing heat loss with burner on	%	0,28	0	0,33	0,21	0,38
Qn - Flue system heat loss with burner on	%	2,71	2,59	2,8	2,41	2,27
Qr - Casing heat loss with burner on	%	1,06	2,06	3,31	2,06	2,17
Qr - Flue system heat loss with burner on	%	1,98	1,7	1,87	1,7	1,83
Qn - Casing heat loss with burner off	%	0,16	0,08	0,14	0,09	
Qr - Casing heat loss with burner off	%	0,17	0,08	0,14	0,08	0,09
WILO circulation pump power absorption	W	400	520	420	520	

Design data	um	360	390	450	480	540
Qn - Casing heat loss with burner on	%	0	0,14	0,38	0	0,21
Qn - Flue system heat loss with burner on	%	2,59	2,47	2,27	2,59	2,41
Qr - Casing heat loss with burner on	%	2,06		2,17	2,06	
Qr - Flue system heat loss with burner on	%	1,7		1,83	1,7	
Qn - Casing heat loss with burner off	%	0,08	0,09		0,08	0,09
Qr - Casing heat loss with burner off	%	0,08		0,09	0,08	
WILO circulation pump power absorption	W	780			1040	

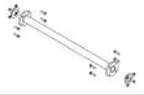
Design data	um	600	660	750	810	900
Qn - Casing heat loss with burner on	%	0,38	0,17	0,38	0,21	0,38
Qn - Flue system heat loss with burner on	%	2,27	2,45	2,27	2,41	2,27
Qr - Casing heat loss with burner on	%	2,17	2,06	2,17	2,06	2,17
Qr - Flue system heat loss with burner on	%	1,83	1,7	1,83	1,7	1,83
Qn - Casing heat loss with burner off	%	0,09				
Qr - Casing heat loss with burner off	%	0,09	0,08	0,09	0,08	0,09
WILO circulation pump power absorption	W	1040	1300		1560	

ACCESSORIES





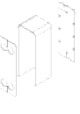



Item	Description	Code
	Self-supporting frame	0STRUPOR03
	Expansion frame	0STRUPOR04
	Single empty cabinet	0ARMSTRU02
	Double empty cabinet	0ARMSTRU03
	Container for neutralising filter	0KSCANEU00
	Filter refill Pmax 350kW - QTY 1 for Outputs up to 350 kW - QTY 2 for Outputs up to 700 kW - QTY 3 for Outputs up to 900 kW	0RICAFIL01
	Flow / return collector unit for plate secondary circuit Plate installation to the left Complete with insulation, DN 65 hydraulic gaskets for the connection of plate collectors and DN 80 hydraulic gaskets for the connection of collectors to the secondary circuit, M16 screws and nuts.	0KITCOLL05
	Flow / return collector unit for plate secondary circuit Plate installation to the right Complete with insulation, DN 65 hydraulic gaskets for the connection of plate collectors and DN 80 hydraulic gaskets for the connection of collectors to the secondary circuit, M16 screws and nuts.	0KITCOLL04
	KIT - Gas collectors for module and single cabinet	0KITCOLL02
	KIT - Gas collectors for double cabinet	0KITCOLL03
	Adapter Ø80/100	0RIDUZIO13
	Suction opening Ø80	0GRIGASP01
	D100 Suction opening	0GRIGASP02
	Collector supporting bracket kit For flue gas duct support in indoor installation. One piece to be purchased for each installed supporting frame. "Bayonet" mounting in frame angle bar, the support is adjustable in height and is secured in place with a socket head screw.	0KSTACOL00

ACCESSORIES

Item	Description	Code
	5 litre expansion vessel kit	0KVASESP00
	120 - 360 kW small size plate insulation (**)	0KISOPIA00
	450 - 600 kW medium size plate insulation (**)	0KISOPIA01
	690 - 900 kW large size plate insulation (**)	0KISOPIA02



(**) Insulation in closed-cell elastomer material 19 mm thick, consisting of a mat to cover the central plate pack, a mat for the front and one for the rear.

FITTINGS FOR MODULES FLUE GAS COLLECTORS Ø 160

Item	Description	Code
	Flue gas pipe for thermal module Ø 160	0COLLFUM03
	Extension L 500 Ø160 (*)	0PROLUNG31
	Extension M/F Ø160 L=1 m (*)	0PROLUNG10
	90° elbow M/F Ø160 (*)	0CURVAXX12
	45° elbow M/F Ø160 (*)	0CURVAXX14
	Tee M/M/F Ø160 (*)	0RACCORT04
	Plug kit for flue gas duct Ø160 (with the possibility to drain condensate)	0SCARCON01
	Elbow 30° M/F Ø160 (*)	0CURVAXX28
	Elbow 15° M/F Ø160 (*)	0CURVAXX30











(*) Items normally not in stock, minimum stock availability time 8 weeks.

FITTINGS FOR MODULES FLUE GAS COLLECTORS Ø 200

Item	Description	Code
	90° elbow M/F Ø200 (*)	0CURVAXX13
	45° elbow M/F Ø200 (*)	0CURVAXX15
	Extension M/F Ø200 L=1 m (*)	0PROLUNG13
	Extension M/F Ø200 L=0.475 (for connection of flue gas pipes, installation with no cabinet) (*)	0PROLUNG15
	Tee M/M/F Ø200 (*)	0RACCORT05
	Plug kit for flue gas duct Ø200 (with the possibility to drain condensate)	0SCARCON02
	Flue gas pipe for thermal module Ø 200	0COLLFUM02
	Extension D 200 L 370 mm for the connection of two adjacent flue gas collectors D 200	0PROLUNG25
	Elbow 30° M/F Ø200 (*)	0CURVAXX27
	Elbow 15° M/F Ø200 (*)	0CURVAXX29





(*) Items normally not in stock, minimum stock availability time 8 weeks.

FITTINGS FOR MODULES FLUE GAS COLLECTORS Ø 250

Item	Description	Code
	Flue gas pipe for thermal module Ø 250	0COLLFUM04
	Extension Ø250 L 370 mm for the connection of two adjacent flue gas collectors Ø250	0PROLUNG26
	Extension Ø250 L 500 mm (*)	0PROLUNG29
	Extension Ø250 L 1000 mm (*)	0PROLUNG30
	Elbow Ø250 90° (*)	0CURVAXX26
	Elbow Ø250 45° (*)	0CURVAXX25
	Elbow Ø250 30° (*)	0CURVAXX24
	Elbow Ø250 15° (*)	0CURVAXX23
	Tee fitting M/M/F Ø250 (*)	0RACCORD28
	Fitting for collector Ø250 with condensate drain	0SCARCON04
	Elbow Ø250 with inspection (*)	0CURVISP06

(*) Items normally not in stock, minimum stock availability time 8 weeks.

OTHER FLUE GAS ACCESSORIES

Item	Description	Code
	Condensate drain trap with horizontal fitting	0SIFCOND00
	M – F Ø 160 – Ø 200 adapter (*)	0RIDUZIO28
	M – F Ø 200 – Ø 250 adapter (*)	0RIDUZIO29
	M – F Ø 250 – Ø 300 adapter (*)	0RIDUZIO30
	Roof terminal Ø100	0TERCOIN01

(*) Items normally not in stock, minimum stock availability time 8 weeks.

MODULAR GENERATOR FOR INDOOR INSTALLATION ON FRAME

Direct collector configuration (**)

Model	Gas type	Code	Nominal heat input (Qn)	Heat output (50-30°C)	Modules
			kW	kW	Nr (nr x [model])
WALL MODULE 45	NATURAL GAS	KIQXX2SD45	40,0	41,5	1 (1 x 45)
WALL MODULE 60	NATURAL GAS	KIQXX2SD60	60,0	62,8	1 (1 x 60)
WALL MODULE 85	NATURAL GAS	KIQXX2SD85	81,0	84,8	1 (1 x 85)
WALL MODULE 90 (**)	NATURAL GAS	KIQXX2SD90	80,0	83,0	2 (2 x 45)
WALL MODULE 105 (**)	NATURAL GAS	KIQXX2SDA1	100,0	104,3	2 (1 x 60 + 1 x 45)
WALL MODULE 120	NATURAL GAS	KIQXX2SD1C	115,0	122,0	1 (1 x 120)
WALL MODULE 150	NATURAL GAS	KIQXX2SD1F	140,0	148,7	1 (1 x 150)
WALL MODULE 170	NATURAL GAS	KIQXX2SD1H	162,0	169,6	2 (2 x 85)
WALL MODULE 205	NATURAL GAS	KIQXX2SDA2	196,0	206,8	2 (1 x 85 + 1 x 120)
WALL MODULE 240	NATURAL GAS	KIQXX2SD2E	230,0	244,0	2 (2 x 120)
WALL MODULE 270	NATURAL GAS	KIQXX2SD2H	255,0	270,7	2 (1 x 120 + 1 x 150)
WALL MODULE 300	NATURAL GAS	KIQXX2SD3A	280,0	297,4	2 (2 x 150)
WALL MODULE 325	NATURAL GAS	KIQXX2SDC3	311,0	328,8	3 (1 x 85 + 2 x 120)
WALL MODULE 360	NATURAL GAS	KIQXX2SD3G	345,0	366,0	3 (3 x 120)
WALL MODULE 390	NATURAL GAS	KIQXX2SD3J	370,0	392,7	3 (2 x 120 + 1 x 150)
WALL MODULE 420	NATURAL GAS	KIQXX2SD4C	395,0	419,4	3 (1 x 120 + 2 x 150)
WALL MODULE 450	NATURAL GAS	KIQXX2SD4F	420,0	446,1	3 (3 x 150)
WALL MODULE 480	NATURAL GAS	KIQXX2SD4I	460,0	488,0	4 (4 x 120)
WALL MODULE 510	NATURAL GAS	KIQXX2SD5B	485,0	514,7	4 (3 x 120 + 1 x 150)
WALL MODULE 540	NATURAL GAS	KIQXX2SD5E	510,0	541,4	4 (2 x 120 + 2 x 150)
WALL MODULE 570	NATURAL GAS	KIQXX2SD5H	535,0	568,1	4 (1 x 120 + 3 x 150)
WALL MODULE 600	NATURAL GAS	KIQXX2SD6A	560,0	594,8	4 (4 x 150)
WALL MODULE 630	NATURAL GAS	KIQXX2SD6D	600,0	636,7	5 (4 x 120 + 1 x 150)
WALL MODULE 660	NATURAL GAS	KIQXX2SD6G	625,0	663,4	5 (3 x 120 + 2 x 150)
WALL MODULE 690	NATURAL GAS	KIQXX2SD6J	650,0	690,1	5 (2 x 120 + 3 x 150)
WALL MODULE 720	NATURAL GAS	KIQXX2SD7C	675,0	716,8	5 (1 x 120 + 4 x 150)
WALL MODULE 750	NATURAL GAS	KIQXX2SD7F	700,0	743,5	5 (5 x 150)
WALL MODULE 780	NATURAL GAS	KIQXX2SD7I	740,0	785,4	6 (4 x 120 + 2 x 150)
WALL MODULE 810	NATURAL GAS	KIQXX2SD8B	765,0	812,1	6 (3x120 + 3 x 150)
WALL MODULE 870	NATURAL GAS	KIQXX2SD8H	815,0	865,5	6 (1 x 120 + 5 x 150)
WALL MODULE 900	NATURAL GAS	KIQXX2SD9A	840,0	892,2	6 (6 x 150)

(*) It is mandatory to combine a hydraulic separator or a plate exchanger to separate the primary circuit (cascade side) from the secondary circuit (plant side)

(**) Versions of modular generators offered to create a low power heating system, spread on 2 heat generators instead of 1

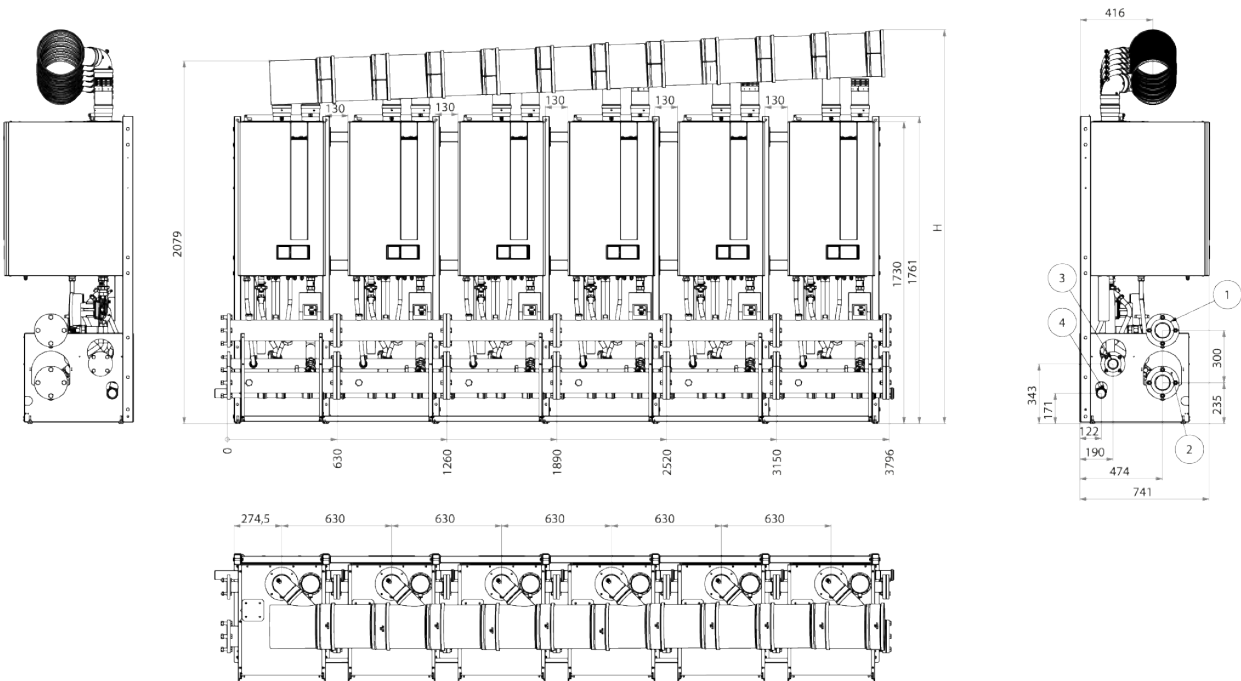

- 1 DN 80 PN 6 flanged primary circuit flow
- 2 DN 80 PN 6 flanged primary circuit return
- 3 DN 50 PN 6 flanged gas inlet
- 4 DN 50 condensate drain

Configuration with hydraulic separator

Model	Gas type	Code	Nominal heat input (Qn)	Heat output (50-30°C)	Modules
			kW	kW	Nr (nr x [model])
WALL MODULE 45	NATURAL GAS	KIQXX2SA45	40,0	41,5	1 (1 x 45)
WALL MODULE 60	NATURAL GAS	KIQXX2SA60	60,0	62,8	1 (1 x 60)
WALL MODULE 85	NATURAL GAS	KIQXX2SA85	81,0	84,8	1 (1 x 85)
WALL MODULE 90 (**)	NATURAL GAS	KIQXX2SA90	80,0	83,0	2 (2 x 45)
WALL MODULE 105 (**)	NATURAL GAS	KIQXX2SAA1	100,0	104,3	2 (1 x 60 + 1 x 45)
WALL MODULE 120	NATURAL GAS	KIQXX2SA1C	115,0	122,0	1 (1 x 120)
WALL MODULE 150	NATURAL GAS	KIQXX2SA1F	140,0	148,7	1 (1 x 150)
WALL MODULE 170	NATURAL GAS	KIQXX2SA1H	162,0	169,6	2 (2 x 85)
WALL MODULE 205	NATURAL GAS	KIQXX2SAA2	196,0	206,8	2 (1 x 85 + 1 x 120)
WALL MODULE 240	NATURAL GAS	KIQXX2SA2E	230,0	244,0	2 (2 x 120)
WALL MODULE 270	NATURAL GAS	KIQXX2SA2H	255,0	270,7	2 (1 x 120 + 1 x 150)
WALL MODULE 300	NATURAL GAS	KIQXX2SA3A	280,0	297,4	2 (2 x 150)
WALL MODULE 325	NATURAL GAS	KIQXX2SAC3	311,0	328,8	3 (1 x 85 + 2 x 120)
WALL MODULE 360	NATURAL GAS	KIQXX2SA3G	345,0	366,0	3 (3 x 120)
WALL MODULE 390	NATURAL GAS	KIQXX2SA3J	370,0	392,7	3 (2 x 120 + 1 x 150)
WALL MODULE 420	NATURAL GAS	KIQXX2SA4C	395,0	419,4	3 (1 x 120 + 2 x 150)
WALL MODULE 450	NATURAL GAS	KIQXX2SA4F	420,0	446,1	3 (3 x 150)
WALL MODULE 480	NATURAL GAS	KIQXX2SA4I	460,0	488,0	4 (4 x 120)
WALL MODULE 510	NATURAL GAS	KIQXX2SA5B	485,0	514,7	4 (3 x 120 + 1 x 150)
WALL MODULE 540	NATURAL GAS	KIQXX2SA5E	510,0	541,4	4 (2 x 120 + 2 x 150)
WALL MODULE 570	NATURAL GAS	KIQXX2SA5H	535,0	568,1	4 (1 x 120 + 3 x 150)
WALL MODULE 600	NATURAL GAS	KIQXX2SA6A	560,0	594,8	4 (4 x 150)
WALL MODULE 630	NATURAL GAS	KIQXX2SA6D	600,0	636,7	5 (4 x 120 + 1 x 150)
WALL MODULE 660	NATURAL GAS	KIQXX2SA6G	625,0	663,4	5 (3 x 120 + 2 x 150)
WALL MODULE 690	NATURAL GAS	KIQXX2SA6J	650,0	690,1	5 (2 x 120 + 3 x 150)
WALL MODULE 720	NATURAL GAS	KIQXX2SA7C	675,0	716,8	5 (1 x 120 + 4 x 150)
WALL MODULE 750	NATURAL GAS	KIQXX2SA7F	700,0	743,5	5 (5 x 150)
WALL MODULE 780	NATURAL GAS	KIQXX2SA7I	740,0	785,4	6 (4 x 120 + 2 x 150)
WALL MODULE 810	NATURAL GAS	KIQXX2SA8B	765,0	812,1	6 (3x120 + 3 x 150)
WALL MODULE 870	NATURAL GAS	KIQXX2SA8H	815,0	865,5	6 (1 x 120 + 5 x 150)
WALL MODULE 900	NATURAL GAS	KIQXX2SA9A	840,0	892,2	6 (6 x 150)

(**) Versions of modular generators offered to create a low power heating system, spread on 2 heat generators instead of 1

The hydraulic separator can be installed on the left or on the right. The image below shows the system with the separator on the right.

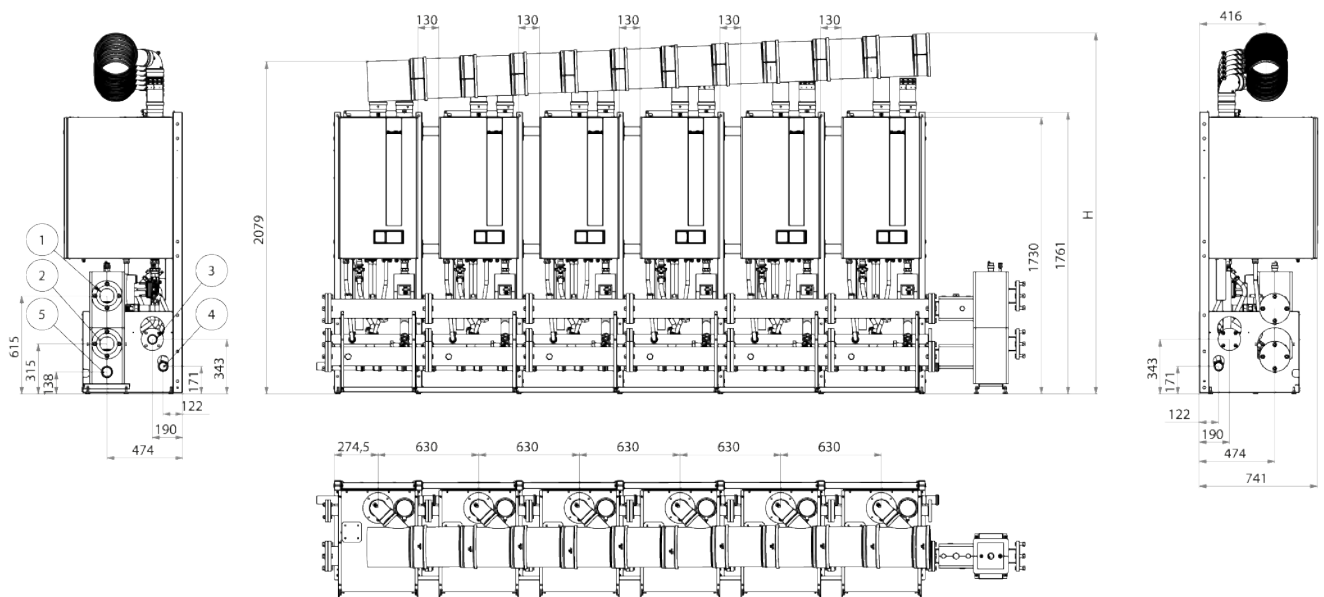

- 1 DN 80 PN 6 flanged connection flow
- 2 PN 6 flanged connection return
- 3 DN 50 flanged connection gas inlet
- 4 DN 50 condensate drain
- 5 Circuit breaker drain for the system G 1 ¼ F

Configuration with plate exchanger (*)

Model	Gas type	Code	Nominal heat input (Qn)	Heat output (50-30°C)	Modules
			kW	kW	Nr (nr x [model])
WALL MODULE 45	NATURAL GAS	KIQXX2SB45	40,0	41,5	1 (1 x 45)
WALL MODULE 60	NATURAL GAS	KIQXX2SB60	60,0	62,8	1 (1 x 60)
WALL MODULE 85	NATURAL GAS	KIQXX2SB85	81,0	84,8	1 (1 x 85)
WALL MODULE 90 (**)	NATURAL GAS	KIQXX2SB90	80,0	83,0	2 (2 x 45)
WALL MODULE 105 (**)	NATURAL GAS	KIQXX2SBA1	100,0	104,3	2 (1 x 60 + 1 x 45)
WALL MODULE 120	NATURAL GAS	KIQXX2SB1C	115,0	122,0	1 (1 x 120)
WALL MODULE 150	NATURAL GAS	KIQXX2SB1F	140,0	148,7	1 (1 x 150)
WALL MODULE 170	NATURAL GAS	KIQXX2SB1H	162,0	169,6	2 (2 x 85)
WALL MODULE 205	NATURAL GAS	KIQXX2SBA2	196,0	206,8	2 (1 x 85 + 1 x 120)
WALL MODULE 240	NATURAL GAS	KIQXX2SB2E	230,0	244,0	2 (2 x 120)
WALL MODULE 270	NATURAL GAS	KIQXX2SB2H	255,0	270,7	2 (1 x 120 + 1 x 150)
WALL MODULE 300	NATURAL GAS	KIQXX2SB3A	280,0	297,4	2 (2 x 150)
WALL MODULE 325	NATURAL GAS	KIQXX2SBC3	311,0	328,8	3 (1 x 85 + 2 x 120)
WALL MODULE 360	NATURAL GAS	KIQXX2SB3G	345,0	366,0	3 (3 x 120)
WALL MODULE 390	NATURAL GAS	KIQXX2SB3J	370,0	392,7	3 (2 x 120 + 1 x 150)
WALL MODULE 420	NATURAL GAS	KIQXX2SB4C	395,0	419,4	3 (1 x 120 + 2 x 150)
WALL MODULE 450	NATURAL GAS	KIQXX2SB4F	420,0	446,1	3 (3 x 150)
WALL MODULE 480	NATURAL GAS	KIQXX2SB4I	460,0	488,0	4 (4 x 120)
WALL MODULE 510	NATURAL GAS	KIQXX2SB5B	485,0	514,7	4 (3 x 120 + 1 x 150)
WALL MODULE 540	NATURAL GAS	KIQXX2SB5E	510,0	541,4	4 (2 x 120 + 2 x 150)
WALL MODULE 570	NATURAL GAS	KIQXX2SB5H	535,0	568,1	4 (1 x 120 + 3 x 150)
WALL MODULE 600	NATURAL GAS	KIQXX2SB6A	560,0	594,8	4 (4 x 150)
WALL MODULE 630	NATURAL GAS	KIQXX2SB6D	600,0	636,7	5 (4 x 120 + 1 x 150)
WALL MODULE 660	NATURAL GAS	KIQXX2SB6G	625,0	663,4	5 (3 x 120 + 2 x 150)
WALL MODULE 690	NATURAL GAS	KIQXX2SB6J	650,0	690,1	5 (2 x 120 + 3 x 150)
WALL MODULE 720	NATURAL GAS	KIQXX2SB7C	675,0	716,8	5 (1 x 120 + 4 x 150)
WALL MODULE 750	NATURAL GAS	KIQXX2SB7F	700,0	743,5	5 (5 x 150)
WALL MODULE 780	NATURAL GAS	KIQXX2SB7I	740,0	785,4	6 (4 x 120 + 2 x 150)
WALL MODULE 810	NATURAL GAS	KIQXX2SB8B	765,0	812,1	6 (3x120 + 3 x 150)
WALL MODULE 870	NATURAL GAS	KIQXX2SB8H	815,0	865,5	6 (1 x 120 + 5 x 150)
WALL MODULE 900	NATURAL GAS	KIQXX2SB9A	840,0	892,2	6 (6 x 150)

(*) the collectors to connect the secondary circuit of the plate exchanger to the system downstream the cascade are excluded from the article code

(**) Versions of modular generators offered to create a low power heating system, spread on 2 heat generators instead of 1

The exchanger can be installed on the left or on the right. The image below shows the system with the exchanger on the right.

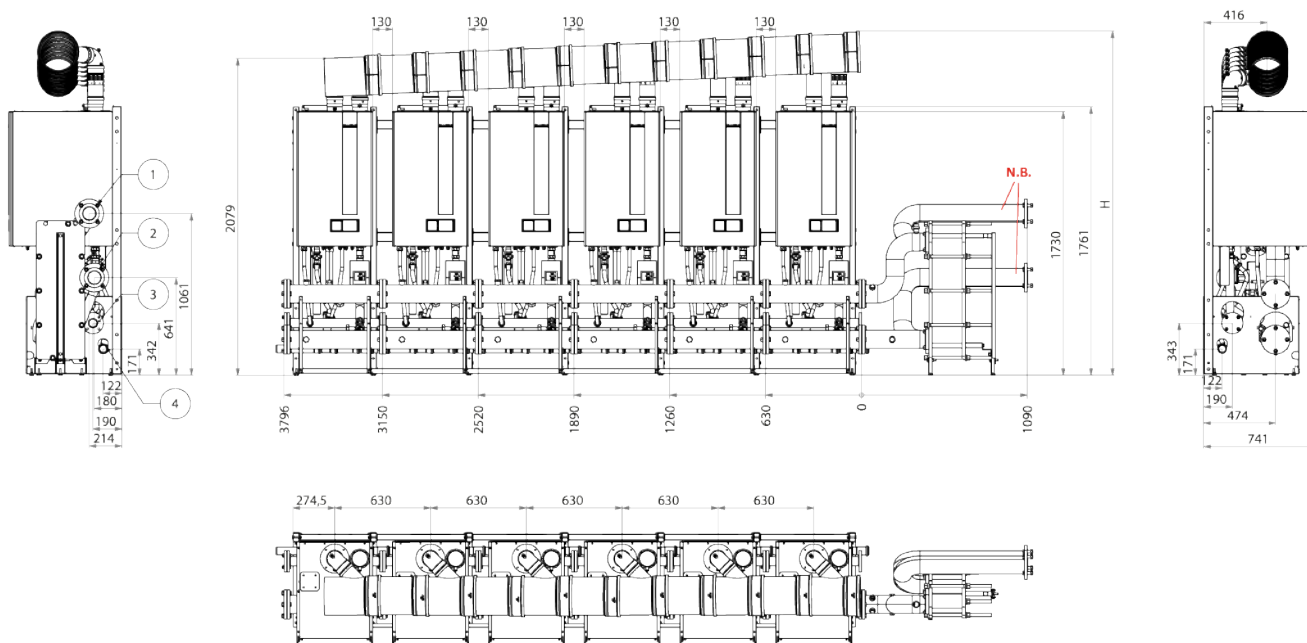

- 1 DN 80 PN 6 flanged connection flow
- 2 PN 6 flanged connection return
- 3 DN 50 flanged connection gas inlet
- 4 DN 50 condensate drain

N.B. The connecting collector kit for the secondary circuit is optional

BACK TO BACK MODULAR GENERATOR FOR INDOOR INSTALLATION ON FRAME

Direct collector configuration (*)

Model	Gas type	Code	Nominal heat input (Q _n)	Heat output (50-30°C)	Modules
			kW	kW	Nr (nr x [model])
WALL MODULE 90	NATURAL GAS	KIRXX2SD90	80	83	2 (2 x 45)
WALL MODULE 120	NATURAL GAS	KIRXX2SD1C	120	125,6	2 (2 x 60)
WALL MODULE 145	NATURAL GAS	KIRXX2SDE1	141	147,6	2 (1 x 60 + 1 x 85)
WALL MODULE 170	NATURAL GAS	KIRXX2SD1H	162	169,6	2 (2 x 85)
WALL MODULE 180	NATURAL GAS	KIRXX2SD1I	180	188,4	3 (3 x 60)
WALL MODULE 205	NATURAL GAS	KIRXX2SDA2	201	210,4	3 (2 x 60 + 1 x 85)
WALL MODULE 240	NATURAL GAS	KIRXX2SD2E	230	244	2 (2 x 120)
WALL MODULE 255	NATURAL GAS	KIRXX2SDF2	243	254,4	3 (3 x 85)
WALL MODULE 270	NATURAL GAS	KIRXX2SD2H	255	270,7	2 (1 x 120 + 1 x 150)
WALL MODULE 300	NATURAL GAS	KIRXX2SD3A	280	297,4	2 (2 x 150)
WALL MODULE 360	NATURAL GAS	KIRXX2SD3G	345	366	3 (3 x 120)
WALL MODULE 390	NATURAL GAS	KIRXX2SD3J	370	392,7	3 (2 x 120 + 1 x 150)
WALL MODULE 450	NATURAL GAS	KIRXX2SD4F	420	446,1	3 (3 x 150)
WALL MODULE 480	NATURAL GAS	KIRXX2SD4I	460	488	4 (4 x 120)
WALL MODULE 540	NATURAL GAS	KIRXX2SD5E	510	541,4	4 (2 x 120 + 2 x 150)
WALL MODULE 600	NATURAL GAS	KIRXX2SD6A	560	594,8	4 (4 x 150)
WALL MODULE 660	NATURAL GAS	KIRXX2SD6G	625	663,4	5 (3 x 120 + 2 x 150)
WALL MODULE 750	NATURAL GAS	KIRXX2SD7F	700	743,5	5 (5 x 150)
WALL MODULE 810	NATURAL GAS	KIRXX2SD8B	765	812,1	6 (3 x 120 + 3 x 150)
WALL MODULE 900	NATURAL GAS	KIRXX2SD9A	840	892,2	6 (6 x 150)

(*) It is mandatory to combine a hydraulic separator or a plate exchanger to separate the primary circuit (cascade side) from the secondary circuit (plant side)

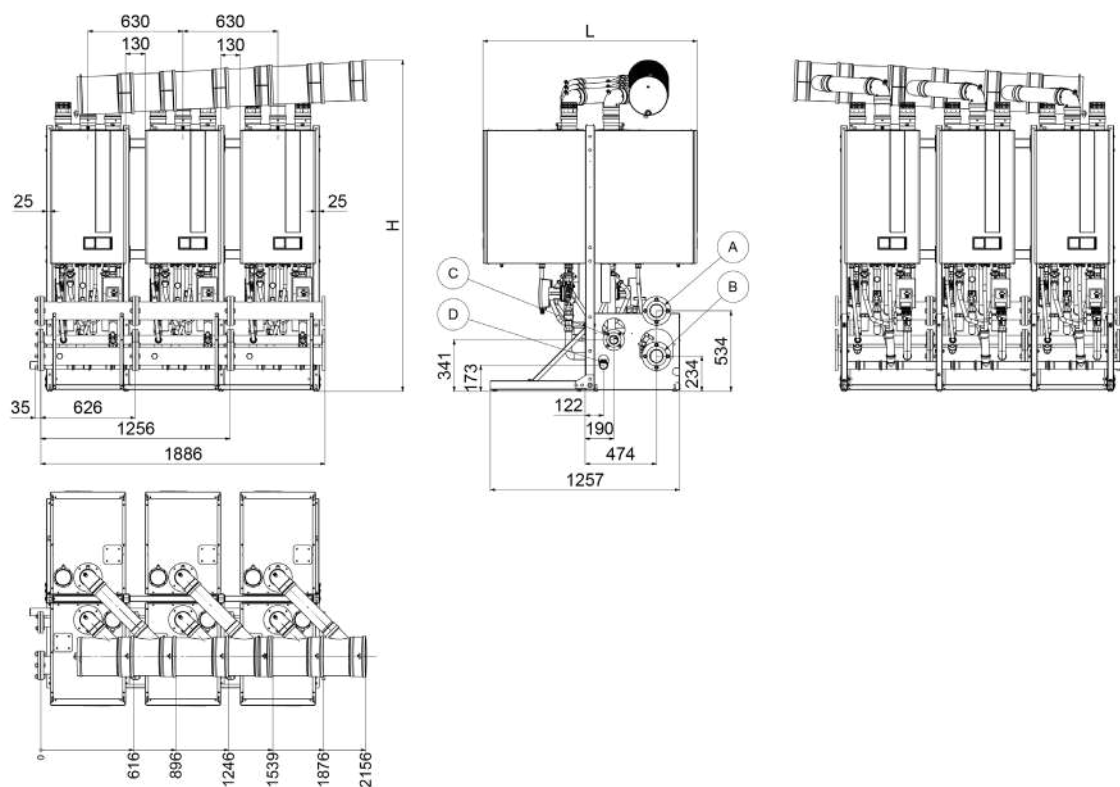

- A** DN 80 Pn6 flanged primary circuit flow
- B** DN 80 Pn6 flanged primary circuit return
- C** DN 50 Pn6 flanged gas inlet
- D** DN 50 condensate drain

Configuration with hydraulic separator

Model	Gas type	Code	Nominal heat input (Q _n)	Heat output (50-30°C)	Modules
			kW	kW	Nr (nr x [model])
WALL MODULE 90	NATURAL GAS	KIRXX2SA90	80	83	2 (2 x 45)
WALL MODULE 120	NATURAL GAS	KIRXX2SA1C	120	125,6	2 (2 x 60)
WALL MODULE 145	NATURAL GAS	KIRXX2SAE1	141	147,6	2 (1 x 60 + 1 x 85)
WALL MODULE 170	NATURAL GAS	KIRXX2SA1H	162	169,6	2 (2 x 85)
WALL MODULE 180	NATURAL GAS	KIRXX2SA1I	180	188,4	3 (3 x 60)
WALL MODULE 205	NATURAL GAS	KIRXX2SAA2	201	210,4	3 (2 x 60 + 1 x 85)
WALL MODULE 240	NATURAL GAS	KIRXX2SA2E	230	244	2 (2 x 120)
WALL MODULE 255	NATURAL GAS	KIRXX2SAF2	243	254,4	3 (3 x 85)
WALL MODULE 270	NATURAL GAS	KIRXX2SA2H	255	270,7	2 (1 x 120 + 1 x 150)
WALL MODULE 300	NATURAL GAS	KIRXX2SA3A	280	297,4	2 (2 x 150)
WALL MODULE 360	NATURAL GAS	KIRXX2SA3G	345	366	3 (3 x 120)
WALL MODULE 390	NATURAL GAS	KIRXX2SA3J	370	392,7	3 (2 x 120 + 1 x 150)
WALL MODULE 450	NATURAL GAS	KIRXX2SA4F	420	446,1	3 (3 x 150)
WALL MODULE 480	NATURAL GAS	KIRXX2SA4I	460	488	4 (4 x 120)
WALL MODULE 540	NATURAL GAS	KIRXX2SA5E	510	541,4	4 (2 x 120 + 2 x 150)
WALL MODULE 600	NATURAL GAS	KIRXX2SA6A	560	594,8	4 (4 x 150)
WALL MODULE 660	NATURAL GAS	KIRXX2SA6G	625	663,4	5 (3 x 120 + 2 x 150)
WALL MODULE 750	NATURAL GAS	KIRXX2SA7F	700	743,5	5 (5 x 150)
WALL MODULE 810	NATURAL GAS	KIRXX2SA8B	765	812,1	6 (3 x 120 + 3 x 150)
WALL MODULE 900	NATURAL GAS	KIRXX2SA9A	840	892,2	6 (6 x 150)

The hydraulic separator can be installed on the left or on the right. The image below shows the system with the separator on the right.

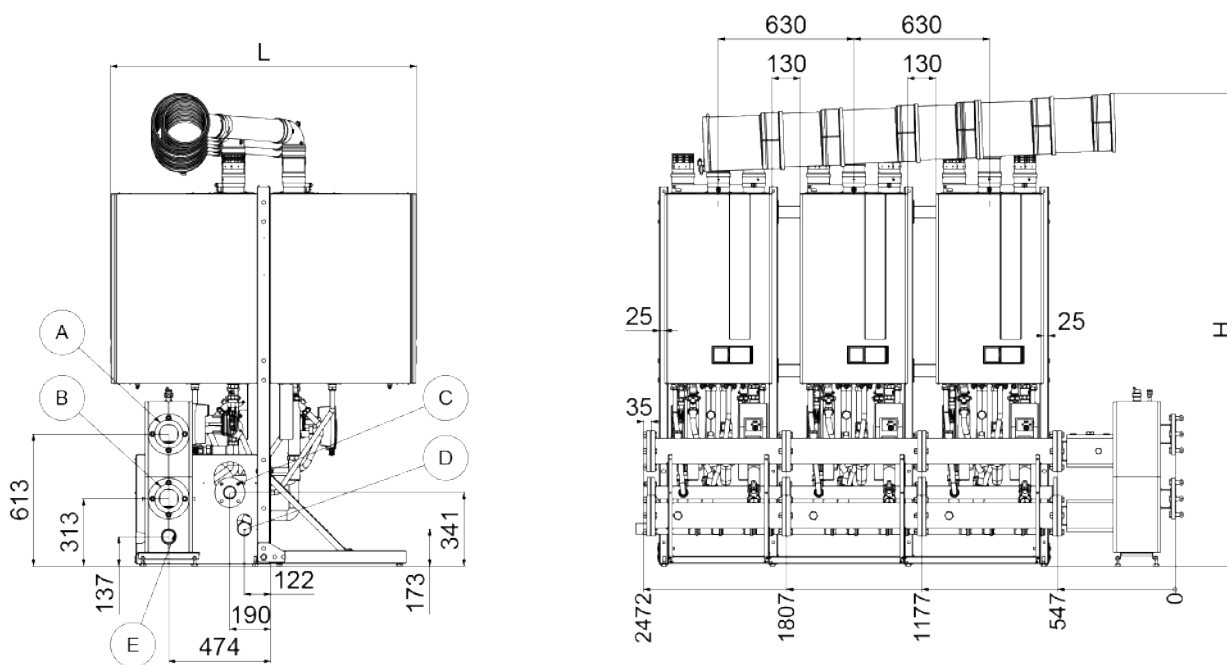

- A DN 80 Pn6 flanged primary circuit flow
- B DN 80 Pn6 flanged primary circuit return
- C DN 50 Pn6 flanged gas inlet
- D DN 50 condensate drain
- E Circuit breaker drain for the system G 1 ¼ F

Configuration with plate exchanger (*)

Model	Gas type	Code	Nominal heat input (Qn)	Heat output (50-30°C)	Modules
			kW	kW	Nr (nr x [model])
WALL MODULE 90	NATURAL GAS	KIRXX2SB90	80	83	2 (2 x 45)
WALL MODULE 120	NATURAL GAS	KIRXX2SB1C	120	125,6	2 (2 x 60)
WALL MODULE 145	NATURAL GAS	KIRXX2SBE1	141	147,6	2 (1 x 60 + 1 x 85)
WALL MODULE 170	NATURAL GAS	KIRXX2SB1H	162	169,6	2 (2 x 85)
WALL MODULE 180	NATURAL GAS	KIRXX2SB1I	180	188,4	3 (3 x 60)
WALL MODULE 205	NATURAL GAS	KIRXX2SBA2	201	210,4	3 (2 x 60 + 1 x 85)
WALL MODULE 240	NATURAL GAS	KIRXX2SB2E	230	244	2 (2 x 120)
WALL MODULE 255	NATURAL GAS	KIRXX2SBF2	243	254,4	3 (3 x 85)
WALL MODULE 270	NATURAL GAS	KIRXX2SB2H	255	270,7	2 (1 x 120 + 1 x 150)
WALL MODULE 300	NATURAL GAS	KIRXX2SB3A	280	297,4	2 (2 x 150)
WALL MODULE 360	NATURAL GAS	KIRXX2SB3G	345	366	3 (3 x 120)
WALL MODULE 390	NATURAL GAS	KIRXX2SB3J	370	392,7	3 (2 x 120 + 1 x 150)
WALL MODULE 450	NATURAL GAS	KIRXX2SB4F	420	446,1	3 (3 x 150)
WALL MODULE 480	NATURAL GAS	KIRXX2SB4I	460	488	4 (4 x 120)
WALL MODULE 540	NATURAL GAS	KIRXX2SB5E	510	541,4	4 (2 x 120 + 2 x 150)
WALL MODULE 600	NATURAL GAS	KIRXX2SB6A	560	594,8	4 (4 x 150)
WALL MODULE 660	NATURAL GAS	KIRXX2SB6G	625	663,4	5 (3 x 120 + 2 x 150)
WALL MODULE 750	NATURAL GAS	KIRXX2SB7F	700	743,5	5 (5 x 150)
WALL MODULE 810	NATURAL GAS	KIRXX2SB8B	765	812,1	6 (3 x 120 + 3 x 150)
WALL MODULE 900	NATURAL GAS	KIRXX2SB9A	840	892,2	6 (6 x 150)

(*) the collectors to connect the secondary circuit of the plate exchanger to the system downstream the cascade are excluded from the article code

The exchanger can be installed on the left or on the right. The image below shows the system with the exchanger on the right.

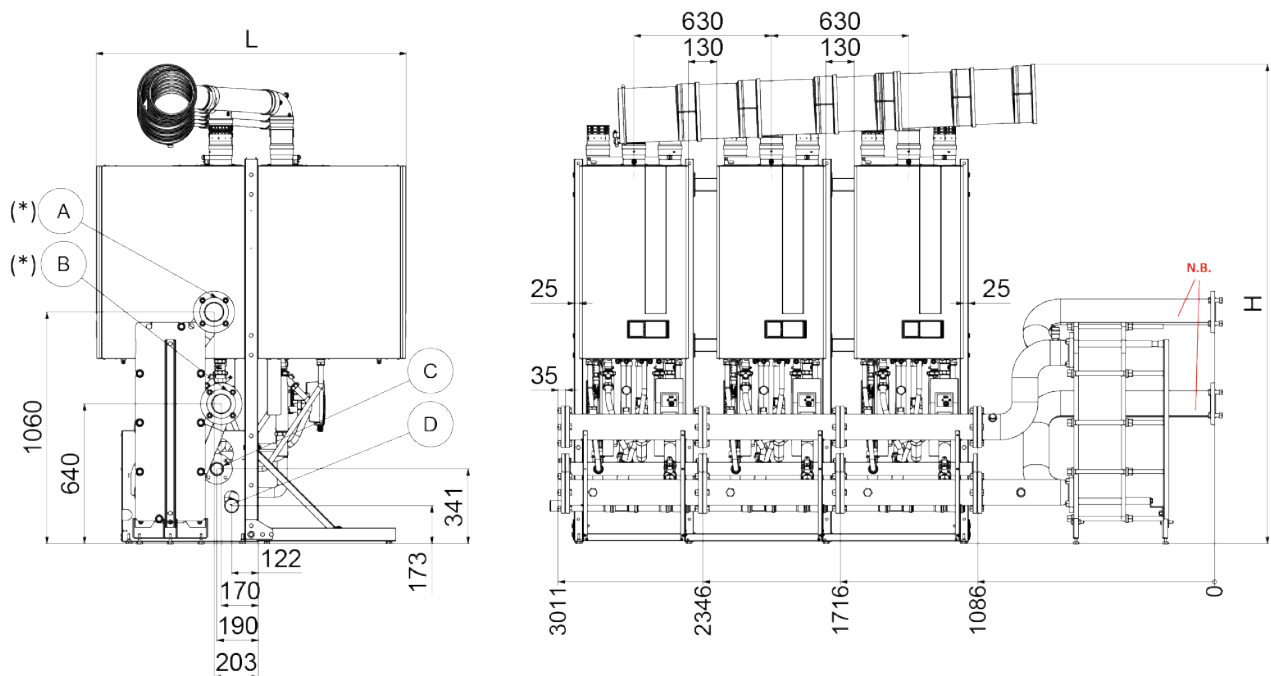

- A** DN 80 Pn6 flanged primary circuit flow
- B** DN 80 Pn6 flanged primary circuit return
- C** DN 50 Pn6 flanged gas inlet
- D** DN 50 condensate drain

N.B. The connecting collector kit for the secondary circuit is optional

MODULAR GENERATOR FOR OUTDOOR INSTALLATION INSIDE CABINET

Direct collector configuration (**)

Model	Gas type	Code	Nominal heat input (Qn)	Heat output (50-30°C)	Modules
			kW	kW	Nr (nr x [model])
CABINET MODULE 45	NATURAL GAS	KIQXX2SO45	40,0	41,5	1 (1 x 45)
CABINET MODULE 60	NATURAL GAS	KIQXX2SO60	60,0	62,8	1 (1 x 60)
CABINET MODULE 85	NATURAL GAS	KIQXX2SO85	81,0	84,8	1 (1 x 85)
CABINET MODULE 90 (**)	NATURAL GAS	KIQXX2SO90	80,0	83,0	2 (2 x 45)
CABINET MODULE 105 (**)	NATURAL GAS	KIQXX2SOA1	100,0	104,3	2 (1 x 60 + 1 x 45)
CABINET MODULE 120	NATURAL GAS	KIQXX2SO1C	115,0	122,0	1 (1 x 120)
CABINET MODULE 150	NATURAL GAS	KIQXX2SO1F	140,0	148,7	1 (1 x 150)
CABINET MODULE 170	NATURAL GAS	KIQXX2SO1H	162,0	169,6	2 (2 x 85)
CABINET MODULE 205	NATURAL GAS	KIQXX2SOA2	196,0	206,8	2 (1 x 85 + 1 x 120)
CABINET MODULE 240	NATURAL GAS	KIQXX2SO2E	230,0	244,0	2 (2 x 120)
CABINET MODULE 270	NATURAL GAS	KIQXX2SO2H	255,0	270,7	2 (1 x 120 + 1 x 150)
CABINET MODULE 300	NATURAL GAS	KIQXX2SO3A	280,0	297,4	2 (2 x 150)
CABINET MODULE 325	NATURAL GAS	KIQXX2SOC3	311,0	328,8	3 (1 x 85 + 2 x 120)
CABINET MODULE 360	NATURAL GAS	KIQXX2SO3G	345,0	366,0	3 (3 x 120)
CABINET MODULE 390	NATURAL GAS	KIQXX2SO3J	370,0	392,7	3 (2 x 120 + 1 x 150)
CABINET MODULE 420	NATURAL GAS	KIQXX2SO4C	395,0	419,4	3 (1 x 120 + 2 x 150)
CABINET MODULE 450	NATURAL GAS	KIQXX2SO4F	420,0	446,1	3 (3 x 150)
CABINET MODULE 480	NATURAL GAS	KIQXX2SO4I	460,0	488,0	4 (4 x 120)
CABINET MODULE 510	NATURAL GAS	KIQXX2SO5B	485,0	514,7	4 (3 x 120 + 1 x 150)
CABINET MODULE 540	NATURAL GAS	KIQXX2SO5E	510,0	541,4	4 (2 x 120 + 2 x 150)
CABINET MODULE 570	NATURAL GAS	KIQXX2SO5H	535,0	568,1	4 (1 x 120 + 3 x 150)
CABINET MODULE 600	NATURAL GAS	KIQXX2SO6A	560,0	594,8	4 (4 x 150)
CABINET MODULE 630	NATURAL GAS	KIQXX2SO6D	600,0	636,7	5 (4 x 120 + 1 x 150)
CABINET MODULE 660	NATURAL GAS	KIQXX2SO6G	625,0	663,4	5 (3 x 120 + 2 x 150)
CABINET MODULE 690	NATURAL GAS	KIQXX2SO6J	650,0	690,1	5 (2 x 120 + 3 x 150)
CABINET MODULE 720	NATURAL GAS	KIQXX2SO7C	675,0	716,8	5 (1 x 120 + 4 x 150)
CABINET MODULE 750	NATURAL GAS	KIQXX2SO7F	700,0	743,5	5 (5 x 150)
CABINET MODULE 780	NATURAL GAS	KIQXX2SO7I	740,0	785,4	6 (4 x 120 + 2 x 150)
CABINET MODULE 810	NATURAL GAS	KIQXX2SO8B	765,0	812,1	6 (3x120 + 3 x 150)
CABINET MODULE 870	NATURAL GAS	KIQXX2SO8H	815,0	865,5	6 (1 x 120 + 5 x 150)
CABINET MODULE 900	NATURAL GAS	KIQXX2SO9A	840,0	892,2	6 (6 x 150)

(*) It is mandatory to combine a hydraulic separator or a plate exchanger to separate the primary circuit (cascade side) from the secondary circuit (plant side)

(**) Versions of modular generators offered to create a low power heating system, spread on 2 heat generators instead of 1

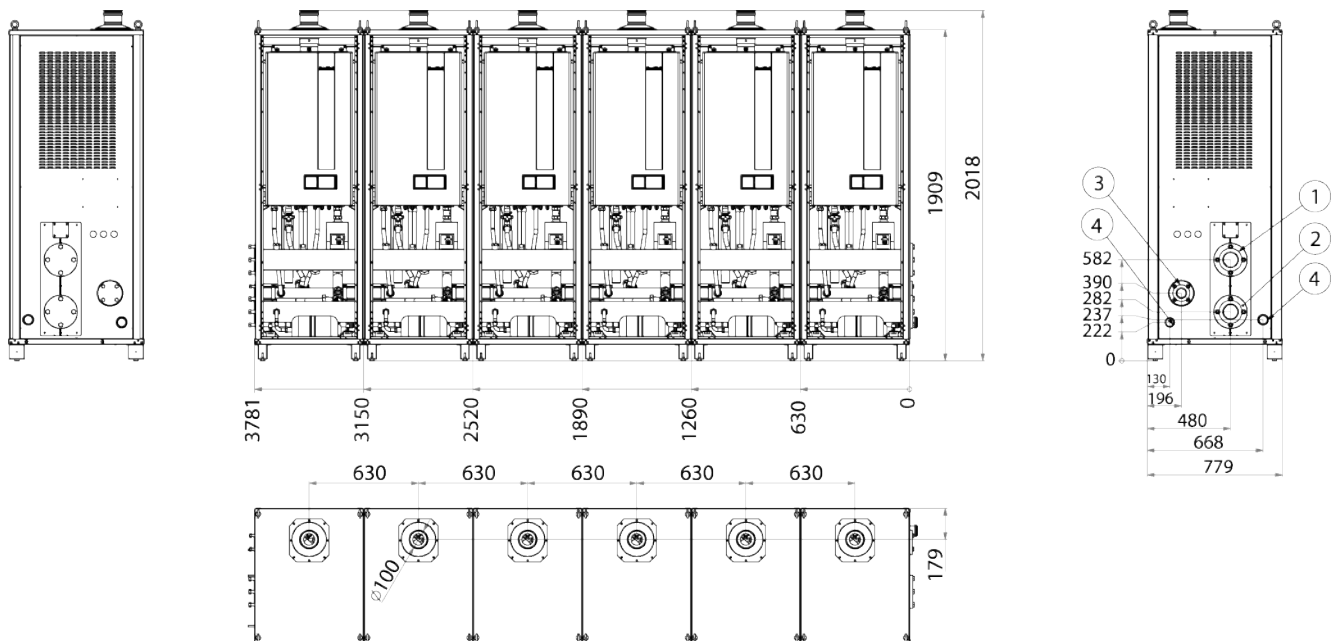

- 1 DN 80 PN 6 flanged connection flow
- 2 PN 6 flanged connection return
- 3 DN 50 flanged connection gas inlet
- 4 DN 50 condensate drain

Configuration with hydraulic separator on the left

Model	Gas type	Code	Nominal heat input (Q _n)	Heat output (50-30°C)	Modules
			kW	kW	Nr (nr x [model])
CABINET MODULE 45	NATURAL GAS	KIQXX2SK45	40,0	41,5	1 (1 x 45)
CABINET MODULE 60	NATURAL GAS	KIQXX2SK60	60,0	62,8	1 (1 x 60)
CABINET MODULE 85	NATURAL GAS	KIQXX2SK85	81,0	84,8	1 (1 x 85)
CABINET MODULE 90 (**)	NATURAL GAS	KIQXX2SK90	80,0	83,0	2 (2 x 45)
CABINET MODULE 105 (**)	NATURAL GAS	KIQXX2SKA1	100,0	104,3	2 (1 x 60 + 1 x 45)
CABINET MODULE 120	NATURAL GAS	KIQXX2SK1C	115,0	122,0	1 (1 x 120)
CABINET MODULE 150	NATURAL GAS	KIQXX2SK1F	140,0	148,7	1 (1 x 150)
CABINET MODULE 170	NATURAL GAS	KIQXX2SK1H	162,0	169,6	2 (2 x 85)
CABINET MODULE 205	NATURAL GAS	KIQXX2SKA2	196,0	206,8	2 (1 x 85 + 1 x 120)
CABINET MODULE 240	NATURAL GAS	KIQXX2SK2E	230,0	244,0	2 (2 x 120)
CABINET MODULE 270	NATURAL GAS	KIQXX2SK2H	255,0	270,7	2 (1 x 120 + 1 x 150)
CABINET MODULE 300	NATURAL GAS	KIQXX2SK3A	280,0	297,4	2 (2 x 150)
CABINET MODULE 325	NATURAL GAS	KIQXX2SKC3	311,0	328,8	3 (1 x 85 + 2 x 120)
CABINET MODULE 360	NATURAL GAS	KIQXX2SK3G	345,0	366,0	3 (3 x 120)
CABINET MODULE 390	NATURAL GAS	KIQXX2SK3J	370,0	392,7	3 (2 x 120 + 1 x 150)
CABINET MODULE 420	NATURAL GAS	KIQXX2SK4C	395,0	419,4	3 (1 x 120 + 2 x 150)
CABINET MODULE 450	NATURAL GAS	KIQXX2SK4F	420,0	446,1	3 (3 x 150)
CABINET MODULE 480	NATURAL GAS	KIQXX2SK4I	460,0	488,0	4 (4 x 120)
CABINET MODULE 510	NATURAL GAS	KIQXX2SK5B	485,0	514,7	4 (3 x 120 + 1 x 150)
CABINET MODULE 540	NATURAL GAS	KIQXX2SK5E	510,0	541,4	4 (2 x 120 + 2 x 150)
CABINET MODULE 570	NATURAL GAS	KIQXX2SK5H	535,0	568,1	4 (1 x 120 + 3 x 150)
CABINET MODULE 600	NATURAL GAS	KIQXX2SK6A	560,0	594,8	4 (4 x 150)
CABINET MODULE 630	NATURAL GAS	KIQXX2SK6D	600,0	636,7	5 (4 x 120 + 1 x 150)
CABINET MODULE 660	NATURAL GAS	KIQXX2SK6G	625,0	663,4	5 (3 x 120 + 2 x 150)
CABINET MODULE 690	NATURAL GAS	KIQXX2SK6J	650,0	690,1	5 (2 x 120 + 3 x 150)
CABINET MODULE 720	NATURAL GAS	KIQXX2SK7C	675,0	716,8	5 (1 x 120 + 4 x 150)
CABINET MODULE 750	NATURAL GAS	KIQXX2SK7F	700,0	743,5	5 (5 x 150)
CABINET MODULE 780	NATURAL GAS	KIQXX2SK7I	740,0	785,4	6 (4 x 120 + 2 x 150)
CABINET MODULE 810	NATURAL GAS	KIQXX2SK8B	765,0	812,1	6 (3x120 + 3 x 150)
CABINET MODULE 870	NATURAL GAS	KIQXX2SK8H	815,0	865,5	6 (1 x 120 + 5 x 150)
CABINET MODULE 900	NATURAL GAS	KIQXX2SK9A	840,0	892,2	6 (6 x 150)

(**) Versions of modular generators offered to create a low power heating system, spread on 2 heat generators instead of 1

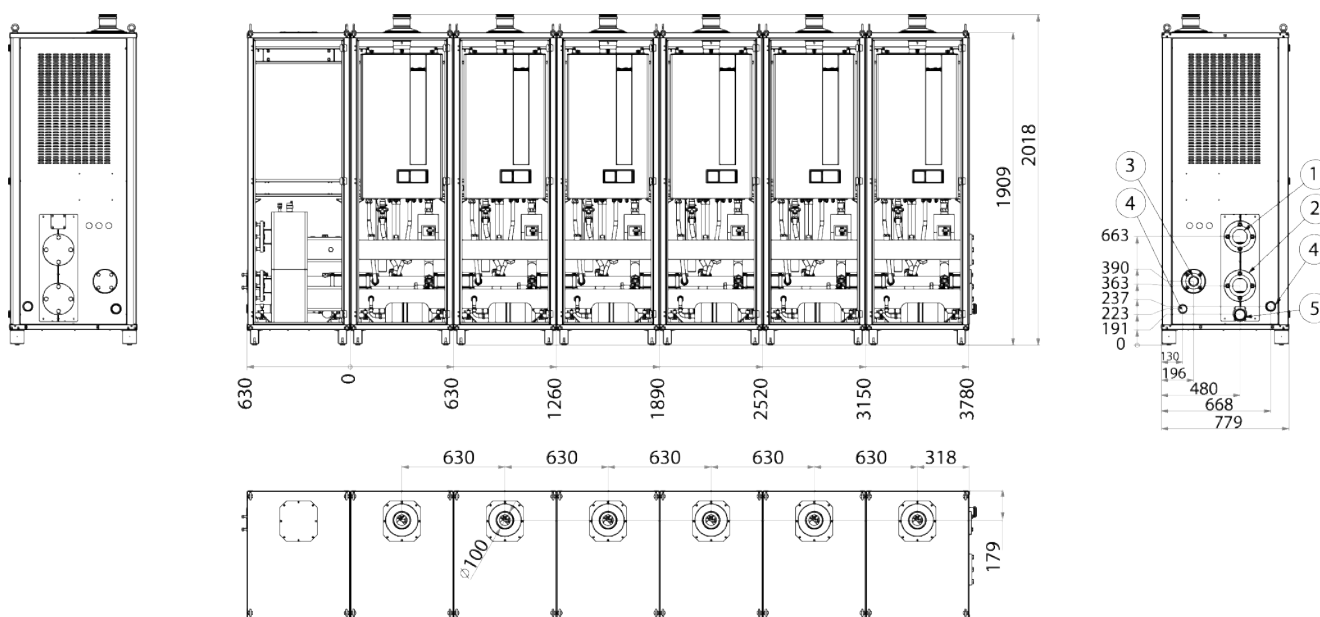

- 1 DN 80 PN 6 flanged connection flow
- 2 PN 6 flanged connection return
- 3 DN 50 flanged connection gas inlet
- 4 DN 50 condensate drain
- 5 Drain for separator 1 1/2 F

Configuration with hydraulic separator on the right					
Model	Gas type	Code	Nominal heat input (Q _n)	Heat output (50-30°C)	Modules
			kW	kW	Nr (nr x [model])
CABINET MODULE 45	NATURAL GAS	KIQXX2SL45	40,0	41,5	1 (1 x 45)
CABINET MODULE 60	NATURAL GAS	KIQXX2SL60	60,0	62,8	1 (1 x 60)
CABINET MODULE 85	NATURAL GAS	KIQXX2SL85	81,0	84,8	1 (1 x 85)
CABINET MODULE 90 (**)	NATURAL GAS	KIQXX2SL90	80,0	83,0	2 (2 x 45)
CABINET MODULE 105 (**)	NATURAL GAS	KIQXX2SLA1	100,0	104,3	2 (1 x 60 + 1 x 45)
CABINET MODULE 120	NATURAL GAS	KIQXX2SL1C	115,0	122,0	1 (1 x 120)
CABINET MODULE 150	NATURAL GAS	KIQXX2SL1F	140,0	148,7	1 (1 x 150)
CABINET MODULE 170	NATURAL GAS	KIQXX2SL1H	162,0	169,6	2 (2 x 85)
CABINET MODULE 205	NATURAL GAS	KIQXX2SLA2	196,0	206,8	2 (1 x 85 + 1 x 120)
CABINET MODULE 240	NATURAL GAS	KIQXX2SL2E	230,0	244,0	2 (2 x 120)
CABINET MODULE 270	NATURAL GAS	KIQXX2SL2H	255,0	270,7	2 (1 x 120 + 1 x 150)
CABINET MODULE 300	NATURAL GAS	KIQXX2SL3A	280,0	297,4	2 (2 x 150)
CABINET MODULE 325	NATURAL GAS	KIQXX2SLC3	311,0	328,8	3 (1 x 85 + 2 x 120)
CABINET MODULE 360	NATURAL GAS	KIQXX2SL3G	345,0	366,0	3 (3 x 120)
CABINET MODULE 390	NATURAL GAS	KIQXX2SL3J	370,0	392,7	3 (2 x 120 + 1 x 150)
CABINET MODULE 420	NATURAL GAS	KIQXX2SL4C	395,0	419,4	3 (1 x 120 + 2 x 150)
CABINET MODULE 450	NATURAL GAS	KIQXX2SL4F	420,0	446,1	3 (3 x 150)
CABINET MODULE 480	NATURAL GAS	KIQXX2SL4I	460,0	488,0	4 (4 x 120)
CABINET MODULE 510	NATURAL GAS	KIQXX2SL5B	485,0	514,7	4 (3 x 120 + 1 x 150)
CABINET MODULE 540	NATURAL GAS	KIQXX2SL5E	510,0	541,4	4 (2 x 120 + 2 x 150)
CABINET MODULE 570	NATURAL GAS	KIQXX2SL5H	535,0	568,1	4 (1 x 120 + 3 x 150)
CABINET MODULE 600	NATURAL GAS	KIQXX2SL6A	560,0	594,8	4 (4 x 150)
CABINET MODULE 630	NATURAL GAS	KIQXX2SL6D	600,0	636,7	5 (4 x 120 + 1 x 150)
CABINET MODULE 660	NATURAL GAS	KIQXX2SL6G	625,0	663,4	5 (3 x 120 + 2 x 150)
CABINET MODULE 690	NATURAL GAS	KIQXX2SL6J	650,0	690,1	5 (2 x 120 + 3 x 150)
CABINET MODULE 720	NATURAL GAS	KIQXX2SL7C	675,0	716,8	5 (1 x 120 + 4 x 150)
CABINET MODULE 750	NATURAL GAS	KIQXX2SL7F	700,0	743,5	5 (5 x 150)
CABINET MODULE 780	NATURAL GAS	KIQXX2SL7I	740,0	785,4	6 (4 x 120 + 2 x 150)
CABINET MODULE 810	NATURAL GAS	KIQXX2SL8B	765,0	812,1	6 (3x120 + 3 x 150)
CABINET MODULE 870	NATURAL GAS	KIQXX2SL8H	815,0	865,5	6 (1 x 120 + 5 x 150)
CABINET MODULE 900	NATURAL GAS	KIQXX2SL9A	840,0	892,2	6 (6 x 150)

(**) Versions of modular generators offered to create a low power heating system, spread on 2 heat generators instead of 1

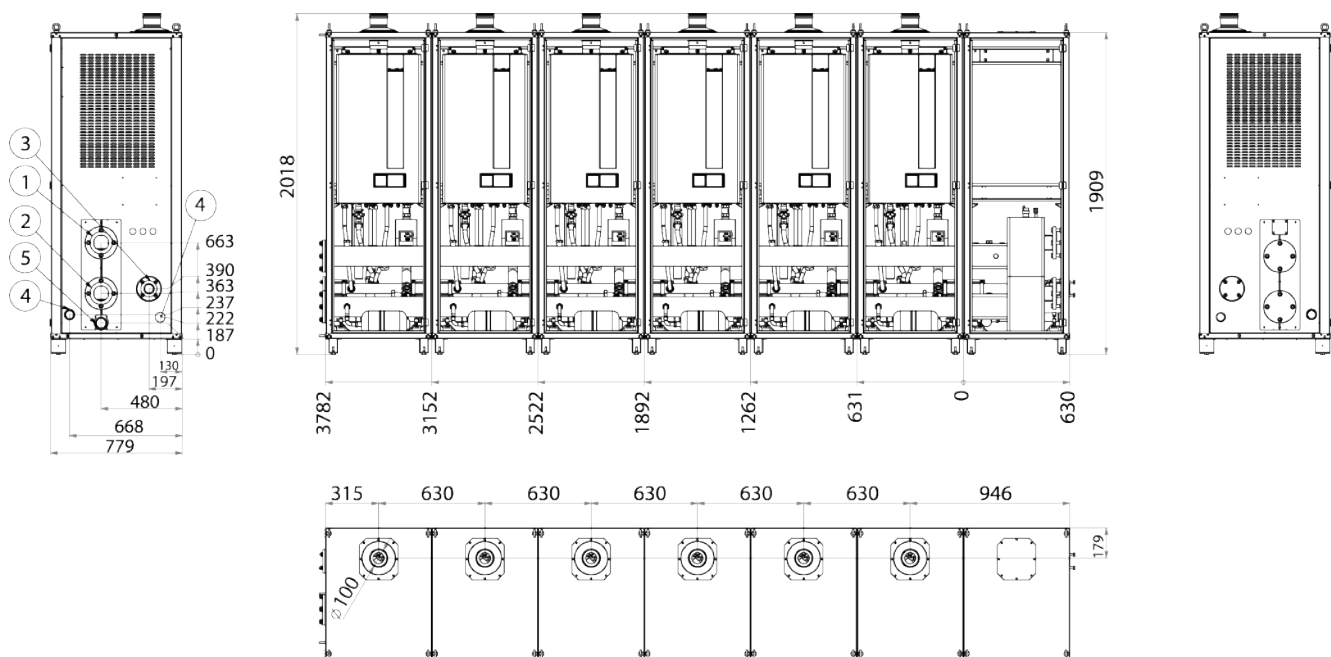

- 1 DN 80 PN 6 flanged connection flow
- 2 PN 6 flanged connection return
- 3 DN 50 flanged connection gas inlet
- 4 DN 50 condensate drain
- 5 Drain for separator 1 ½ F

Configuration with plate exchanger on the left

Model	Gas type	Code	Nominal heat input (Qn)	Heat output (50-30°C)	Modules
			kW	kW	Nr (nr x [model])
CABINET MODULE 45	NATURAL GAS	KIQXX2SM45	40,0	41,5	1 (1 x 45)
CABINET MODULE 60	NATURAL GAS	KIQXX2SM60	60,0	62,8	1 (1 x 60)
CABINET MODULE 85	NATURAL GAS	KIQXX2SM85	81,0	84,8	1 (1 x 85)
CABINET MODULE 90 (**)	NATURAL GAS	KIQXX2SM90	80,0	83,0	2 (2 x 45)
CABINET MODULE 105 (**)	NATURAL GAS	KIQXX2SMA1	100,0	104,3	2 (1 x 60 + 1 x 45)
CABINET MODULE 120	NATURAL GAS	KIQXX2SM1C	115,0	122,0	1 (1 x 120)
CABINET MODULE 150	NATURAL GAS	KIQXX2SM1F	140,0	148,7	1 (1 x 150)
CABINET MODULE 170	NATURAL GAS	KIQXX2SM1H	162,0	169,6	2 (2 x 85)
CABINET MODULE 205	NATURAL GAS	KIQXX2SMA2	196,0	206,8	2 (1 x 85 + 1 x 120)
CABINET MODULE 240	NATURAL GAS	KIQXX2SM2E	230,0	244,0	2 (2 x 120)
CABINET MODULE 270	NATURAL GAS	KIQXX2SM2H	255,0	270,7	2 (1 x 120 + 1 x 150)
CABINET MODULE 300	NATURAL GAS	KIQXX2SM3A	280,0	297,4	2 (2 x 150)
CABINET MODULE 325	NATURAL GAS	KIQXX2SMC3	311,0	328,8	3 (1 x 85 + 2 x 120)
CABINET MODULE 360	NATURAL GAS	KIQXX2SM3G	345,0	366,0	3 (3 x 120)
CABINET MODULE 390	NATURAL GAS	KIQXX2SM3J	370,0	392,7	3 (2 x 120 + 1 x 150)
CABINET MODULE 420	NATURAL GAS	KIQXX2SM4C	395,0	419,4	3 (1 x 120 + 2 x 150)
CABINET MODULE 450	NATURAL GAS	KIQXX2SM4F	420,0	446,1	3 (3 x 150)
CABINET MODULE 480	NATURAL GAS	KIQXX2SM4I	460,0	488,0	4 (4 x 120)
CABINET MODULE 510	NATURAL GAS	KIQXX2SM5B	485,0	514,7	4 (3 x 120 + 1 x 150)
CABINET MODULE 540	NATURAL GAS	KIQXX2SM5E	510,0	541,4	4 (2 x 120 + 2 x 150)
CABINET MODULE 570	NATURAL GAS	KIQXX2SM5H	535,0	568,1	4 (1 x 120 + 3 x 150)
CABINET MODULE 600	NATURAL GAS	KIQXX2SM6A	560,0	594,8	4 (4 x 150)
CABINET MODULE 630	NATURAL GAS	KIQXX2SM6D	600,0	636,7	5 (4 x 120 + 1 x 150)
CABINET MODULE 660	NATURAL GAS	KIQXX2SM6G	625,0	663,4	5 (3 x 120 + 2 x 150)
CABINET MODULE 690	NATURAL GAS	KIQXX2SM6J	650,0	690,1	5 (2 x 120 + 3 x 150)
CABINET MODULE 720	NATURAL GAS	KIQXX2SM7C	675,0	716,8	5 (1 x 120 + 4 x 150)
CABINET MODULE 750	NATURAL GAS	KIQXX2SM7F	700,0	743,5	5 (5 x 150)
CABINET MODULE 780	NATURAL GAS	KIQXX2SM7I	740,0	785,4	6 (4 x 120 + 2 x 150)
CABINET MODULE 810	NATURAL GAS	KIQXX2SM8B	765,0	812,1	6 (3x120 + 3 x 150)
CABINET MODULE 870	NATURAL GAS	KIQXX2SM8H	815,0	865,5	6 (1 x 120 + 5 x 150)
CABINET MODULE 900	NATURAL GAS	KIQXX2SM9A	840,0	892,2	6 (6 x 150)

(**) Versions of modular generators offered to create a low power heating system, spread on 2 heat generators instead of 1

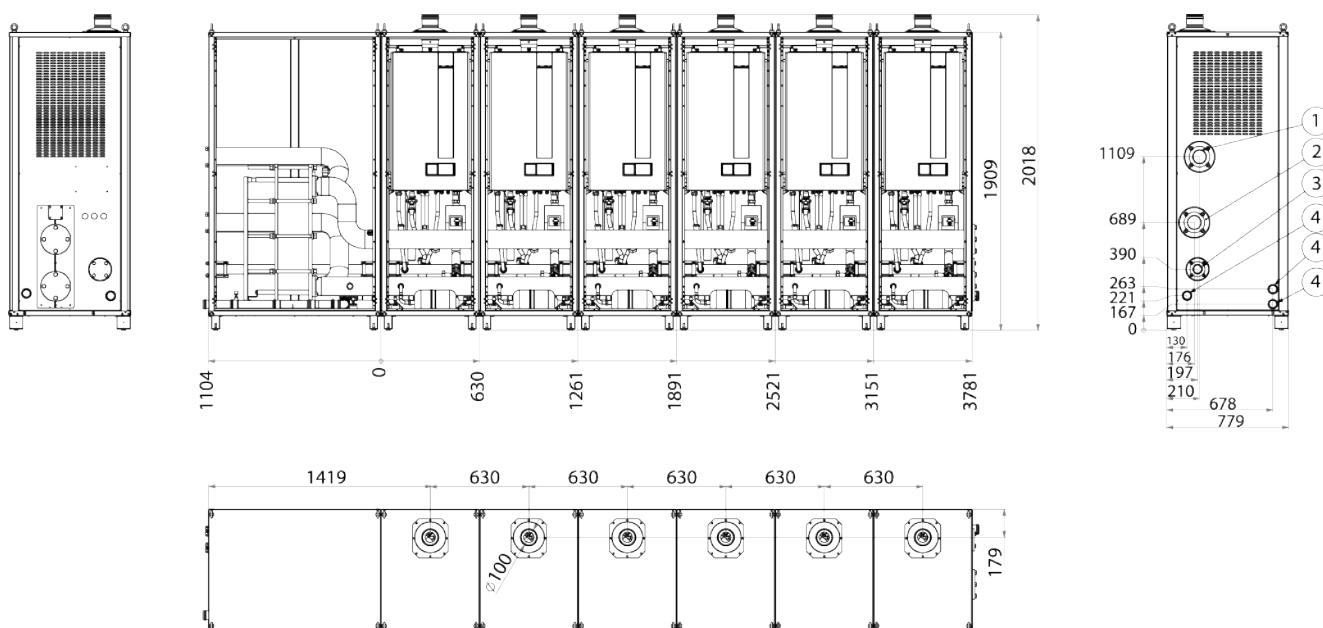

- 1 DN 80 PN 6 flanged connection flow
- 2 PN 6 flanged connection return
- 3 DN 50 flanged connection gas inlet
- 4 DN 50 condensate drain

Configuration with plate exchanger on the right

Model	Gas type	Code	Nominal heat input (Qn)	Heat output (50-30°C)	Modules
			kW	kW	Nr (nr x [model])
CABINET MODULE 45	NATURAL GAS	KIQXX2SN45	40,0	41,5	1 (1 x 45)
CABINET MODULE 60	NATURAL GAS	KIQXX2SN60	60,0	62,8	1 (1 x 60)
CABINET MODULE 85	NATURAL GAS	KIQXX2SN85	81,0	84,8	1 (1 x 85)
CABINET MODULE 90 (**)	NATURAL GAS	KIQXX2SN90	80,0	83,0	2 (2 x 45)
CABINET MODULE 105 (**)	NATURAL GAS	KIQXX2SNA1	100,0	104,3	2 (1 x 60 + 1 x 45)
CABINET MODULE 120	NATURAL GAS	KIQXX2SN1C	115,0	122,0	1 (1 x 120)
CABINET MODULE 150	NATURAL GAS	KIQXX2SN1F	140,0	148,7	1 (1 x 150)
CABINET MODULE 170	NATURAL GAS	KIQXX2SN1H	162,0	169,6	2 (2 x 85)
CABINET MODULE 205	NATURAL GAS	KIQXX2SNA2	196,0	206,8	2 (1 x 85 + 1 x 120)
CABINET MODULE 240	NATURAL GAS	KIQXX2SN2E	230,0	244,0	2 (2 x 120)
CABINET MODULE 270	NATURAL GAS	KIQXX2SN2H	255,0	270,7	2 (1 x 120 + 1 x 150)
CABINET MODULE 300	NATURAL GAS	KIQXX2SN3A	280,0	297,4	2 (2 x 150)
CABINET MODULE 325	NATURAL GAS	KIQXX2SNC3	311,0	328,8	3 (1 x 85 + 2 x 120)
CABINET MODULE 360	NATURAL GAS	KIQXX2SN3G	345,0	366,0	3 (3 x 120)
CABINET MODULE 390	NATURAL GAS	KIQXX2SN3J	370,0	392,7	3 (2 x 120 + 1 x 150)
CABINET MODULE 420	NATURAL GAS	KIQXX2SN4C	395,0	419,4	3 (1 x 120 + 2 x 150)
CABINET MODULE 450	NATURAL GAS	KIQXX2SN4F	420,0	446,1	3 (3 x 150)
CABINET MODULE 480	NATURAL GAS	KIQXX2SN4I	460,0	488,0	4 (4 x 120)
CABINET MODULE 510	NATURAL GAS	KIQXX2SN5B	485,0	514,7	4 (3 x 120 + 1 x 150)
CABINET MODULE 540	NATURAL GAS	KIQXX2SN5E	510,0	541,4	4 (2 x 120 + 2 x 150)
CABINET MODULE 570	NATURAL GAS	KIQXX2SN5H	535,0	568,1	4 (1 x 120 + 3 x 150)
CABINET MODULE 600	NATURAL GAS	KIQXX2SN6A	560,0	594,8	4 (4 x 150)
CABINET MODULE 630	NATURAL GAS	KIQXX2SN6D	600,0	636,7	5 (4 x 120 + 1 x 150)
CABINET MODULE 660	NATURAL GAS	KIQXX2SN6G	625,0	663,4	5 (3 x 120 + 2 x 150)
CABINET MODULE 690	NATURAL GAS	KIQXX2SN6J	650,0	690,1	5 (2 x 120 + 3 x 150)
CABINET MODULE 720	NATURAL GAS	KIQXX2SN7C	675,0	716,8	5 (1 x 120 + 4 x 150)
CABINET MODULE 750	NATURAL GAS	KIQXX2SN7F	700,0	743,5	5 (5 x 150)
CABINET MODULE 780	NATURAL GAS	KIQXX2SN7I	740,0	785,4	6 (4 x 120 + 2 x 150)
CABINET MODULE 810	NATURAL GAS	KIQXX2SN8B	765,0	812,1	6 (3x120 + 3 x 150)
CABINET MODULE 870	NATURAL GAS	KIQXX2SN8H	815,0	865,5	6 (1 x 120 + 5 x 150)
CABINET MODULE 900	NATURAL GAS	KIQXX2SN9A	840,0	892,2	6 (6 x 150)

(**) Versions of modular generators offered to create a low power heating system, spread on 2 heat generators instead of 1

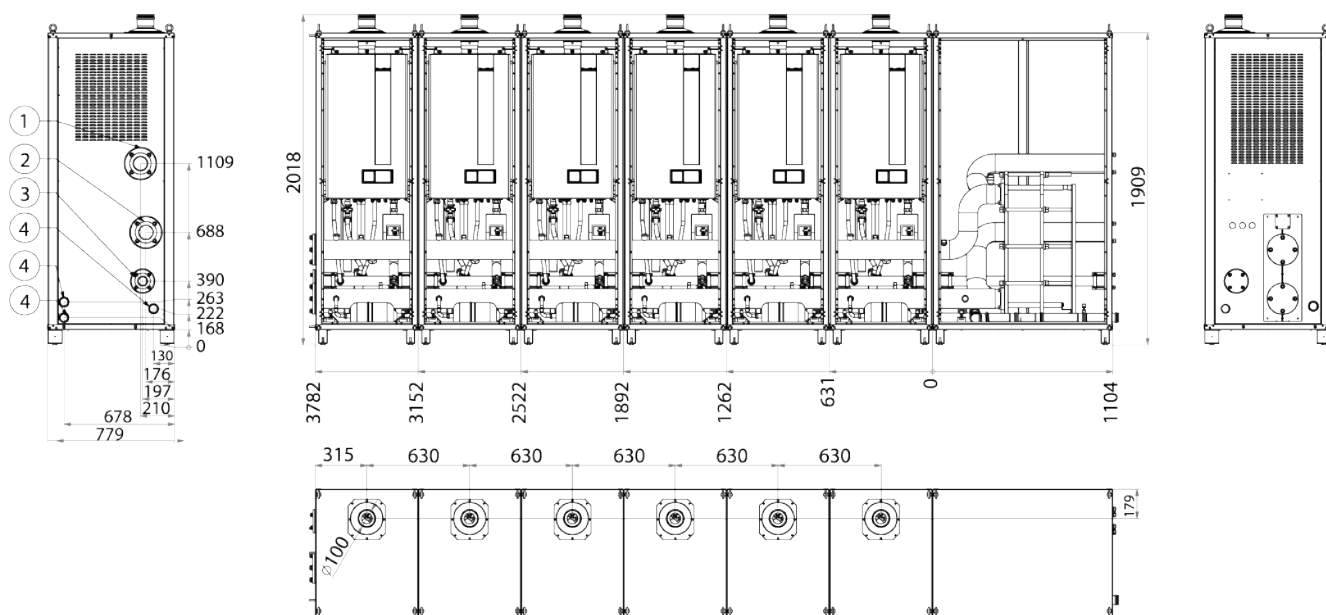

- 1 DN 80 PN 6 flanged connection flow
- 2 PN 6 flanged connection return
- 3 DN 50 flanged connection gas inlet
- 4 DN 50 condensate drain

The manufacturer reserves the right to implement modifications without notice.

Uff. Pub. Fondital - CTC 03 C738 - 02 | Marzo 2021 (03/2021)

FONDITAL S.p.A. Società a unico socio

Via Cerreto, 40

25079 VOBARNO (Brescia) Italia

Tel.: +39 0365 878.31 - Fax: +39 0365 878.304

E-mail: info@fondital.it - Web: www.fondital.com



**COMPANY WITH
QUALITY SYSTEM
CERTIFIED BY DNV GL
= ISO 9001:2015 =**